

SKIPPER S-1800

Sonar

Installation And Operation Manual

Edition : S1800-EM-02.11

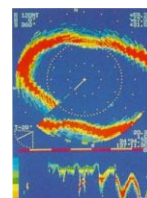
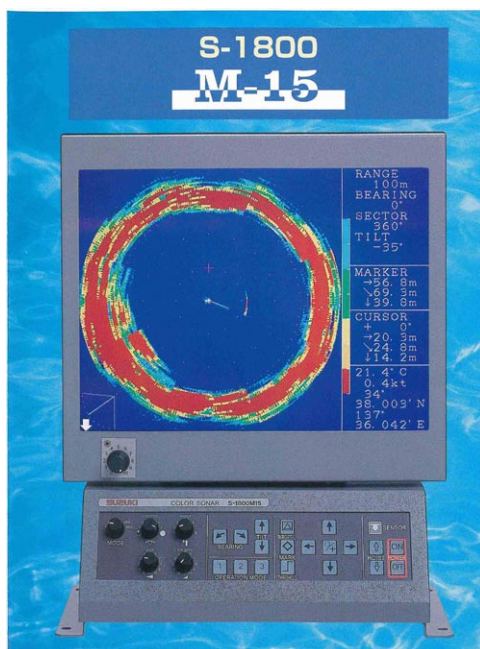

Skipper Electronics A/S
Ryensvingen 5
P.O.Box 151, Manglerud
0612 Oslo, Norway
www.skipper.no

Telephone +47 23 30 22 70
Telefax +47 23 30 22 71
E-mail: skipper@skipper.no
Co.reg.no: NO-965378847 -MVA

SKIPPER

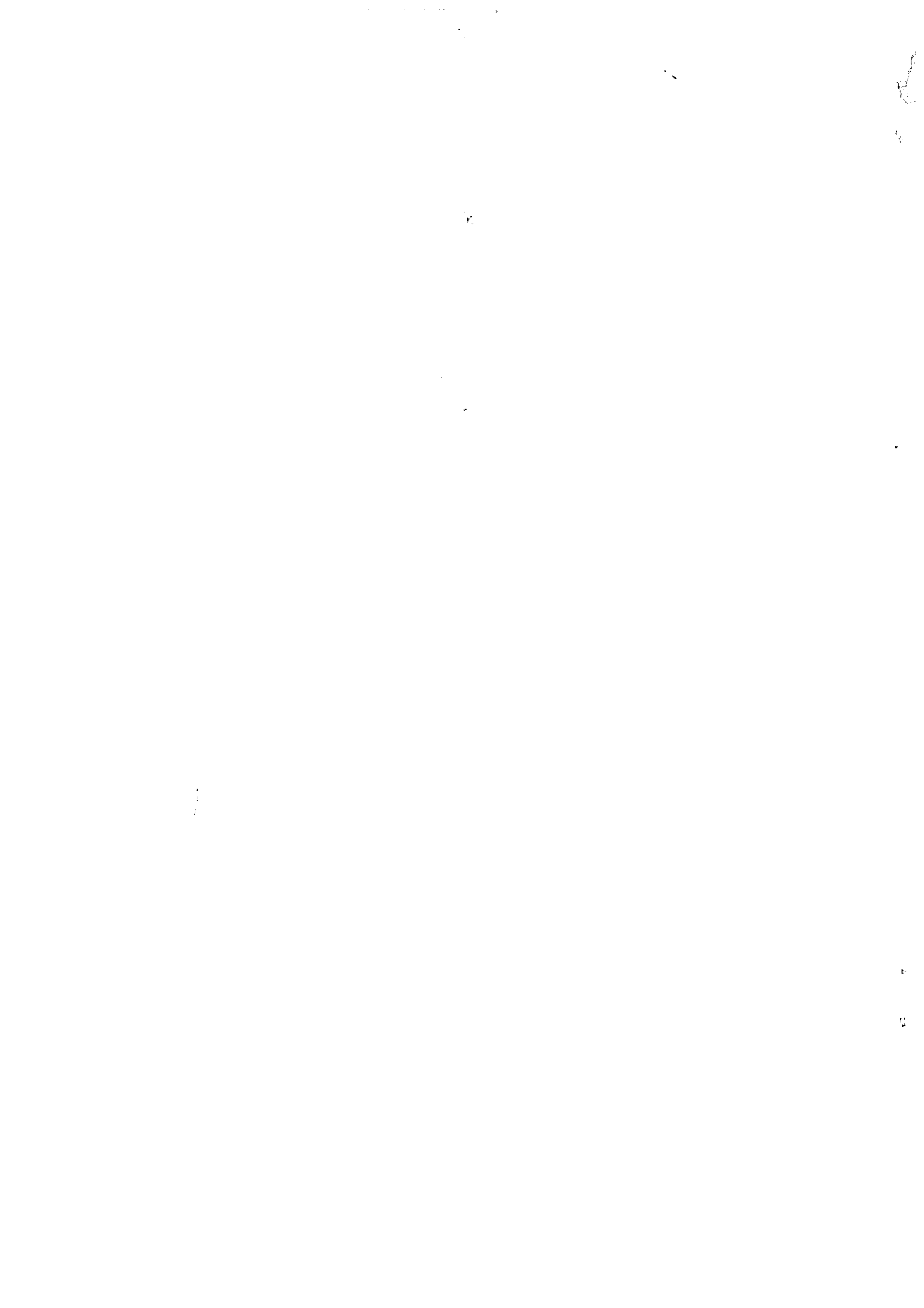

CONTENTS

Chapter 1. NOTES TO USERS	2
INTRODUCTION	3
FOR YOUR SAFETY	5
SUPPLIED COMPONENTS	7
Chapter 2. INSTALLATION	10
Chapter 3. FUNDAMENTALS	42
Chapter 4. FUNCTION SETTINGS	53
INITIAL SETTINGS	54
MENU	57
FUNCTION SETTINGS	60
Chapter 5. SONAR OPERATION	84
OPERATION DIAL	85
OPERATION KEY	88
Chapter 6. OPTION	96
OPTION	96
HOW TO CONNECT CABLE	97
Chapter 7. SPECIFICATIONS	98

Chapter 1

NOTES TO USERS

Thank you for selecting the S-1800.

Before operating this unit, please read this manual thoroughly to ensure correct and safe operation in accordance with the warning instructions and operation procedures.

INTRODUCTION

SYMBOLS	3
INSTRUCTIONS FOR THIS OPERATION MANUAL	3
TURNING ON/OFF THE POWER	4
KEY OPERATION	4

FOR YOUR SAFETY

INSTALLATION SITE REQUIREMENTS	5
MOUNTING CONDITIONS	5
POWER SUPPLY	6
HANDLING	6

SUPPLIED COMPONENTS

SUPPLIED COMPONENTS	7
---------------------------	---

INTRODUCTION

SYMBOLS

- ◎ The following symbols are used in this manual. Please read this manual carefully and take note of these symbols.



: indicates an imminently hazardous situation which, if not avoided, will result in death or serious injury.



: indicates a potentially hazardous situation which, if not avoided, could result in death or serious injury.



: indicates a potentially hazardous situation which, if not avoided, may result in minor injury.

NOTE !

: indicates the contents for the user's reference.

CF

: pages for your reference.

INSTRUCTIONS FOR THIS OPERATION MANUAL

- ◎ This manual should be kept on hand to provide your quick reference whenever you need it. When you give this unit, S-1800, to someone else, make sure to give this manual, too.
- ◎ Any use other than that mentioned in this manual is not guaranteed.
- ◎ The contents in this manual are subject to change without notice or obligation.

INTRODUCTION

TURNING ON THE POWER

- ⦿ When the power ON key is pressed, the power is turned on.

As soon as the power is turned on, the soundome starts to go down.

TURNING OFF THE POWER

- ⦿ When the power OFF key is pressed and held, the power is turned off.

As soon as the power is turned off, the soundome starts to go up.

KEY OPERATION

- ⦿ One short beep will show that you pressed the correct key.

Three short beeps will advise you that a wrong key is pressed.

FOR YOUR SAFETY

INSTALLATION SITE REQUIREMENTS



- ⊙ Do not let flammable gas get in the unit, as this will lead to fires.



- ⊙ For long term trouble-free service, the proposed site for installation should be:
 - Away as much as possible from areas where the unit is likely to be exposed to direct water spray and free as much as possible from shocks and engine vibrations.
 - Away as much as possible from areas of high temperatures or areas where the unit is likely to be exposed to direct sunlight.
- ⊙ To avoid magnetic interference to the display, please keep the unit separated from magnetic equipments such as loud speakers.
 - Also equipments effected by magnetism, compass and tapes etc, should be kept separately from the Display Cabinet.

MOUNTING CONDITIONS



- ⊙ Do not install the S-1800 on unstable or unlevel surfaces.. Failure to observe this condition may result in the unit falling or toppling over, resulting in injury.
- ⊙ Bring wiring to the following attention to avoid getting hurt or causing fire or damage.
 - Run the cables not to touch the rotary obstacles or disturb the operation.
 - Do not use the cables bent, twisted or stretched by force.
 - Do not put heavy thing on the cables.



- ⊙ Always turn off the power before connecting or disconnecting the unit. Pulling the cables may damage the cables themselves and result in fire or electric shock, or fire.

INTRODUCTION

POWER SUPPLY



- ⊙ Please use with the indicated voltage.
Otherwise, it will lead to fires or electric shock.



- ⊙ Make sure to turn off the power by the power "ON/OFF" key on the control panel. Turning on/off the power by the switchboard may cause a serious problem or wrong operation
- ⊙ When starting the vessel engine, make sure the power of this unit is turned off, otherwise it may cause a serious problem or wrong operation.

HANDLING



- ⊙ Do not open the case cover. There is a risk of electric shock if you touch the high voltage conductors.
Electrical installations should be carried out by the qualified staff
- ⊙ When installing the transducer through an opening in the hull bottom, pay attention to intensity and waterproofing. If not, it may cause wrecks.

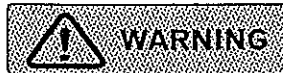





- ⊙ Please use specified fuse.
If not, it could result in serious trouble or fire.
- ⊙ Please use the specified power supply cables.
If not, it could result in fire.
- ⊙ The Hoist Gears and Flange Unit require regular lubrication with grease.
- ⊙ Make sure the voltage between the Flange and the Battery's negative terminal not to exceed 0.65V.
Otherwise due to the electric corrosion the Soundome may be damaged.

SUPPLIED COMPONENTS

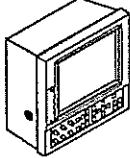
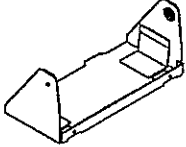
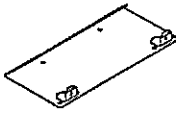
SUPPLIED COMPONENTS

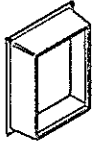
10.4 INCH LCD DISPLAY (S-1800M10)

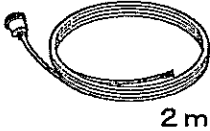

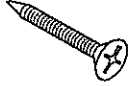
CODE	**HR110			**HR130	
PART	DISPLAY CABINET 	INSTALLATION BRACKET 	MOUNTING PLATE 	HEXAGONAL BOLT 	HOOD 
P. No.	—	34808C	34556C	M6X20-Assy	34535C-Assy
QTY	1	1	1	2	1

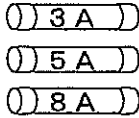
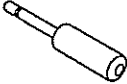
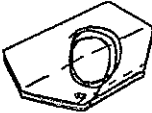
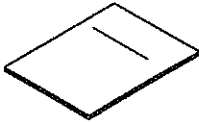
CODE	**HR010				
PART	POWER SUPPLY DISPLAY  2m	TRUSS SCREW 	TAPPING SCREW 		
P. No.	31524D	M8X15	M5X30		
QTY	1	2	6		

CODE	**HR121			
PART	FUSE 	AUDIO PLUG 	DISPLAY CABINET COVER 	OPERATION MANUAL 
P. No.	—	P-110	—	S1800-0PM-E
QTY	EACH 3	1	1	1



NOTE: the code No. is shown on the packages. However, two ** indicates the lot management No.





JOINT PIPE

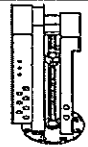
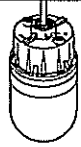

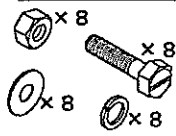
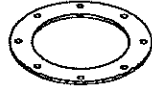
CODE	S-1800H180/80		S-1800H150	
PART	JOINT PIPE 		JOINT PIPE 	
P. No.	32679C		34064C	
QTY	1		1	

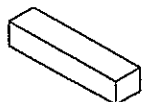

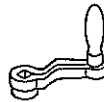
SUPPLIED COMPONENT

HULL UNIT (S-1800H180 or H80)

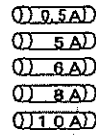
CODE				**HF110	**HF120
PART	HULL UNIT 	SOUNDOME 	PIPE GUIDE 	BOLT SET 	GUM PACKING for FLANGE 
P. No.	—	—	33481C	SUS-M16x55-Ass	30926D
QTY	1	1	3	1	1

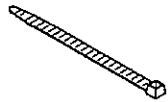

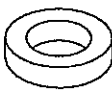
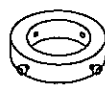
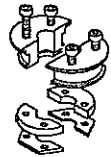
CODE	**HF170 (FOR SOUNDOME)			**HF010	
PART	BATH CORK 	HEX ROD WRENCH  3 mm 5 mm		CRANK HANDLE 	GREASE 
P. No.	(50g)	—		OB-63	(100g)
QTY	1	EACH 1		1	1



CODE	**HF010		**HF002		
	**HF001				
PART	FUSE 		ANP BASE 	BAND 	
P. No.	—		ANP-1	AB-100-1000	
QTY	EACH 3		2	2	

CODE	**HF140				
PART	DUMPER 	FIXING COLLAR 	PIPE CAP 	CAP BOLT 	HEX ROD WRENCH  2 mm 3 mm
P. No.	34924D	32681D-Assy	32682D-Assy	SUS-M4x10	—
QTY	1	2	1	4	EACH 1

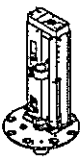
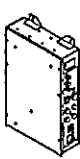

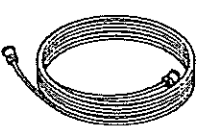
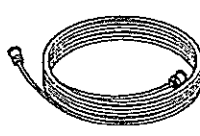
NOTE: the code No. is shown on the packages. However, two ** indicates the lot management No.

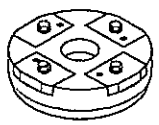
HULL UNIT (S-1800H150)

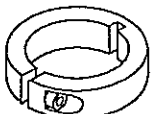
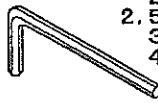
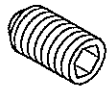
CODE				**HA141	**HA142
	HULL UNIT	CONTROL UNIT	SOUNDOME	SIGNAL CABLE	HOIST CABLE
CODE				 15m	 15m
P. No.	-	-	-	33026D	33027D
QTY	1	1	1	1	1

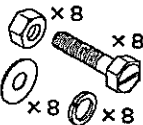
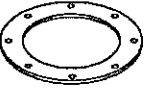
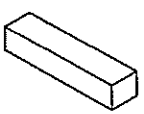
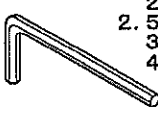
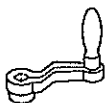
CODE	**HA180	**HA140			
	PIPE GUIDE	PIPE HEAD	STOPPER	HEX ROD WRENCH	SET SCREW
PART		 x4		 1.5 mm 2.5 mm 3 mm 4 mm	
P. No.	34271C-Assy	34066D-Assy	34062D-Assy	-	SUS-M4x6
QTY	1	1	1	1 PER EACH SIZE	4

CODE	**HA110	**HA120	**HA170 (FOR SOUNDOME)	**HA010	
	BOLT SET	GUM PACKING for FLANGE	BATH CORK	HEX ROD WRENCH	CRANK HANDLE
PART	 x8			 2 mm 2.5 mm 3 mm 4 mm	
P. No.	SUS-M20x80Assy	34065C	-	-	OB-63
QTY	1	1	50g X 1	1 PER EACH SIZE	1

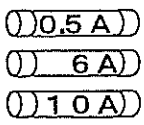
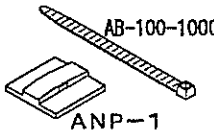
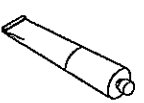
CODE	**HA010				
	SELF BONDING	GREASE	**HA001	**HA002	**HA003
PART			 0.5 A 6 A 10 A	 AB-100-1000 ANP-1	
P. No.	No. 15	-	-	-	PASTE 560
QTY	1	100g X 1	EACH 3	EACH 2	60g X 1

NOTE: the code No. is shown on the packages. However, two ** indicates the lot management No.

INSTALLATION

This chapter explains the installation for sonar monitor and hull unit.

INSTALLATION

INSTALLATION POSITION of HULL UNIT	11
DIMENSIONS (H180/80)	12
DIMENSIONS (H150)	13
TRUNK PIPE INSTALLATION	14
HULL UNIT H180/80 ASSEMBL	19
HULL UNIT H150 ASSEMBLY	26
CONTROL UNIT H150 INSTALLATION	33
DISPLAY UNIT INSTALLATION	34
CONNECTIONS - REAR PANEL	35
CONNECTIONS - H180/80	36
CONNECTIONS - H150	37
WARNING on CONNECTIONS	38
H180/80 INTERNAL CONNECTIONS	39
SOUNDOME CONNECTION	40
H150 INTERNAL CONNECTION	41

INSTALLATION

Satisfy the following conditions and also instructions of operation manual in deciding the trunk pipe mounting site.

Fully discuss about the strength with the shipyard and the installer before determining on the position and the method of installation and necessary materials.

INSTALLATION POSITION

- ◎ Select a position the least influenced from air bubbles, interference or noise.
- It is most advisable to select a position along the keel and within $1/3$ to $1/2$ of the overall length. If this is not possible, install the unit so that the center of the tank comes within 1m from the keel.

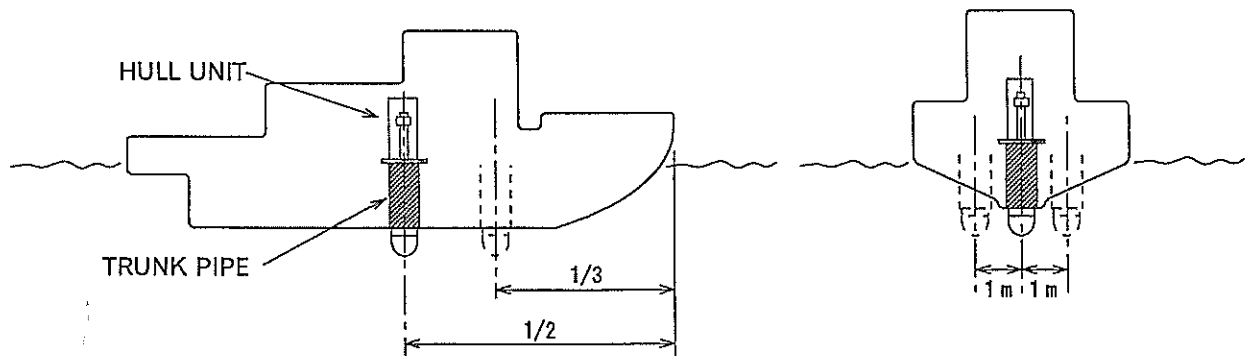

- ◎ Be sure there are no obstacles to interfere the ultrasonic beam when the soundome is lowered.
- ◎ Provide sufficient clearance around the trunk pipe to make maintenance and inspection work.
- ◎ The Bow mark (Δ) on the Hull unit flange should be installed facing the bow of the vessel. However, if this hinders maintenance and inspection and when there is no solution, direct the mark to the opposite (180 degrees) direction toward the stern.

INSTALLATION

DIMENSIONS (H180/80)

HULL CONTROL UNIT

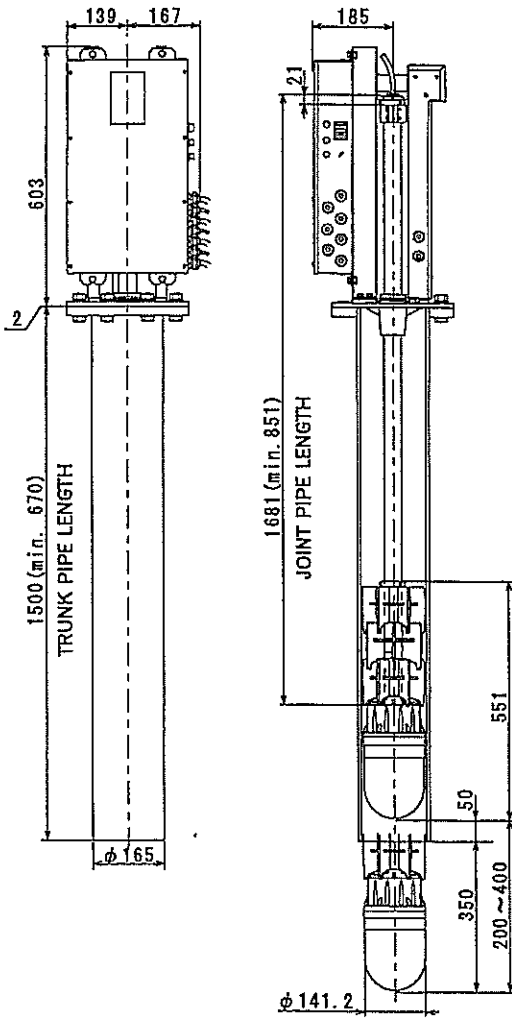

HULL UNIT FLANGE

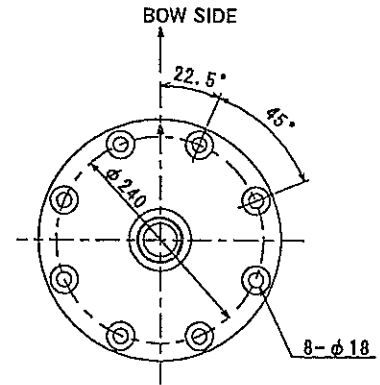

MOUNTING PLATE FOR M10

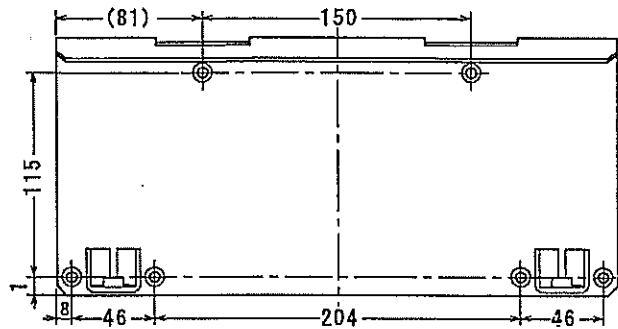

DISPLAY UNIT M10

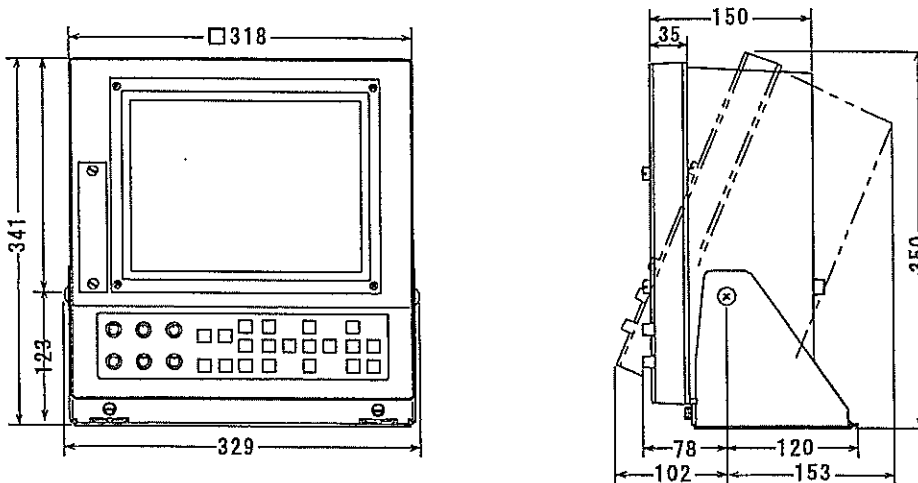

DIMENSIONS (H150)

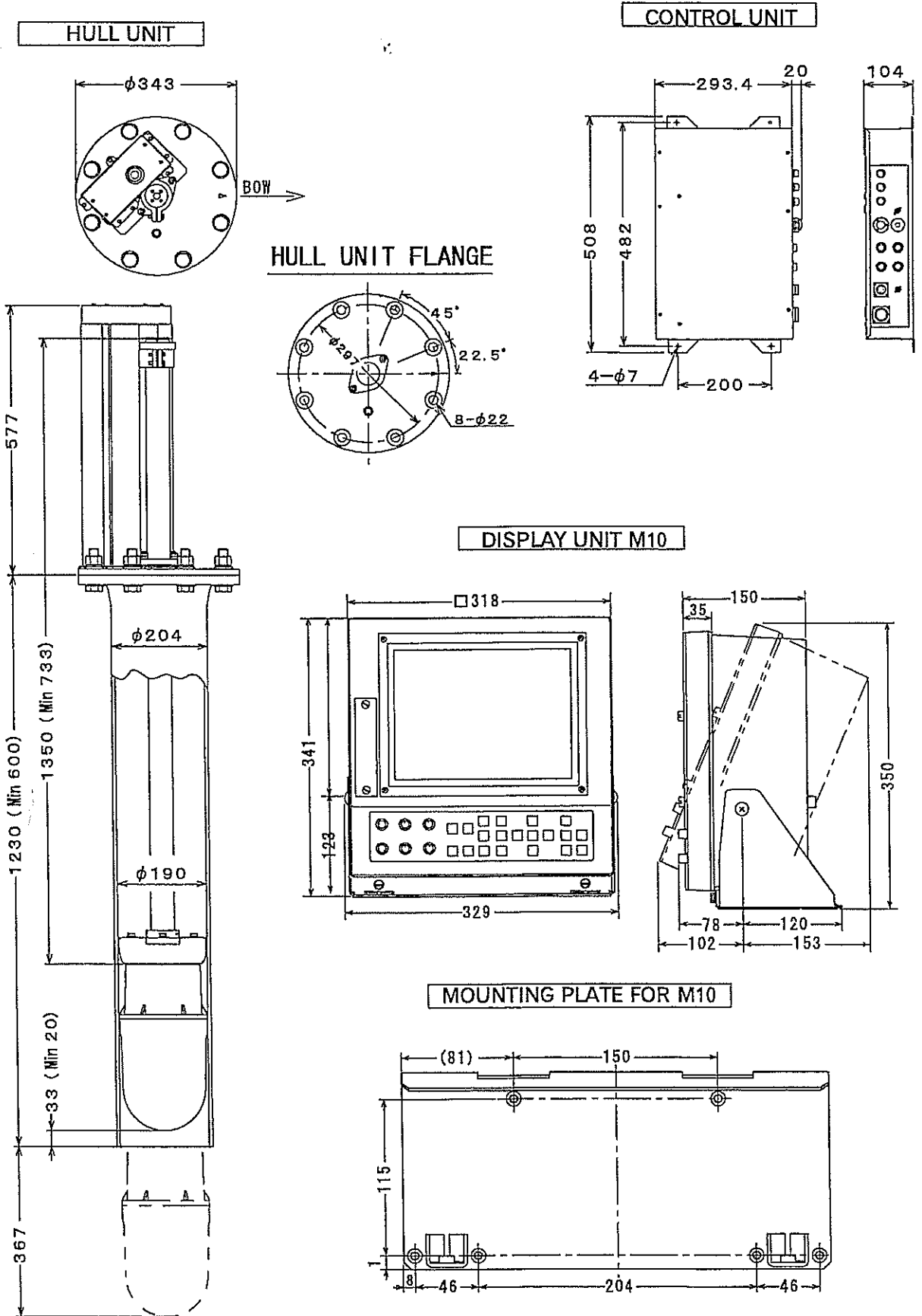

INSTALLATION

TRUNK PIPE INSTALLATION

1-1 MAINTENANCE SPACE (H180/80)

- ◎ When installing the Trunk Pipe, pay full attention to the safety (strength, water-tightness, etc.) and, at the same time, secure a space for maintenance and inspections.
- ◎ Since the hoist-lower unit is not of waterproof structure, keep it away from water drops and splashes.
- ◎ S-1800 180kHz and 80kHz are shipped from the factory with a standard, 1,681 mm Joint Pipe and without Trunk Pipe (options are available) .
- ◎ The Joint Pipe should be at least 181 mm longer than the Trunk Pipe.

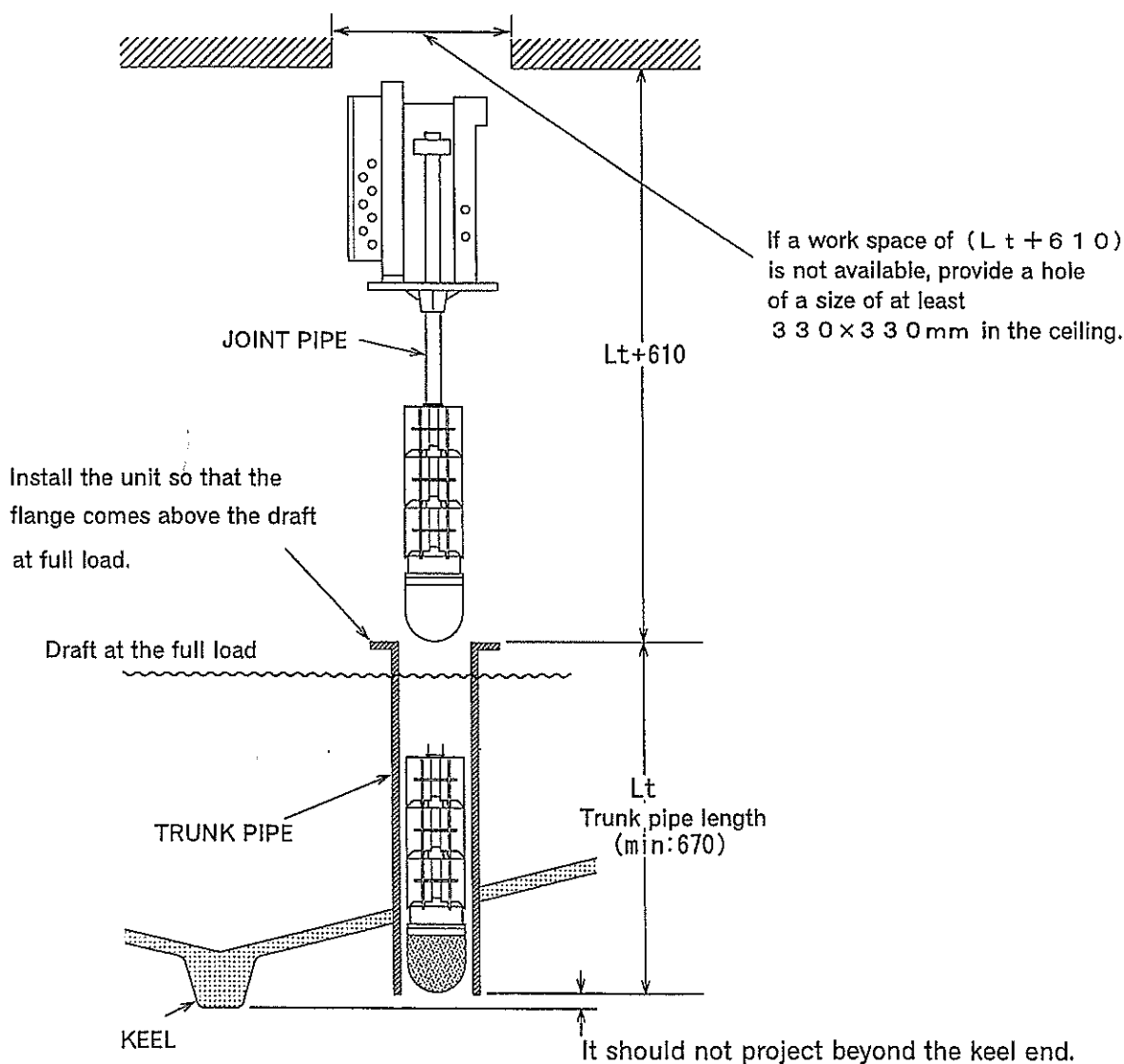

TRUNK PIPE INSTALLATION

1-2 MAINTENANCE SPACE (H150)

- ◎ When installing the Trunk Pipe, pay full attention to the safety (strength, water-tightness, etc.) and, at the same time, secure a space for maintenance and inspections.
- ◎ Since the hoist-lower unit is not of waterproof structure, keep it away from water drops and splashes.
- ◎ S-1800 150kHz is shipped from the factory with a standard, 1,350 mm Joint Pipe and without Trunk Pipe (options are available) .
- ◎ The Joint Pipe should be at least 120 mm longer than the Trunk Pipe.

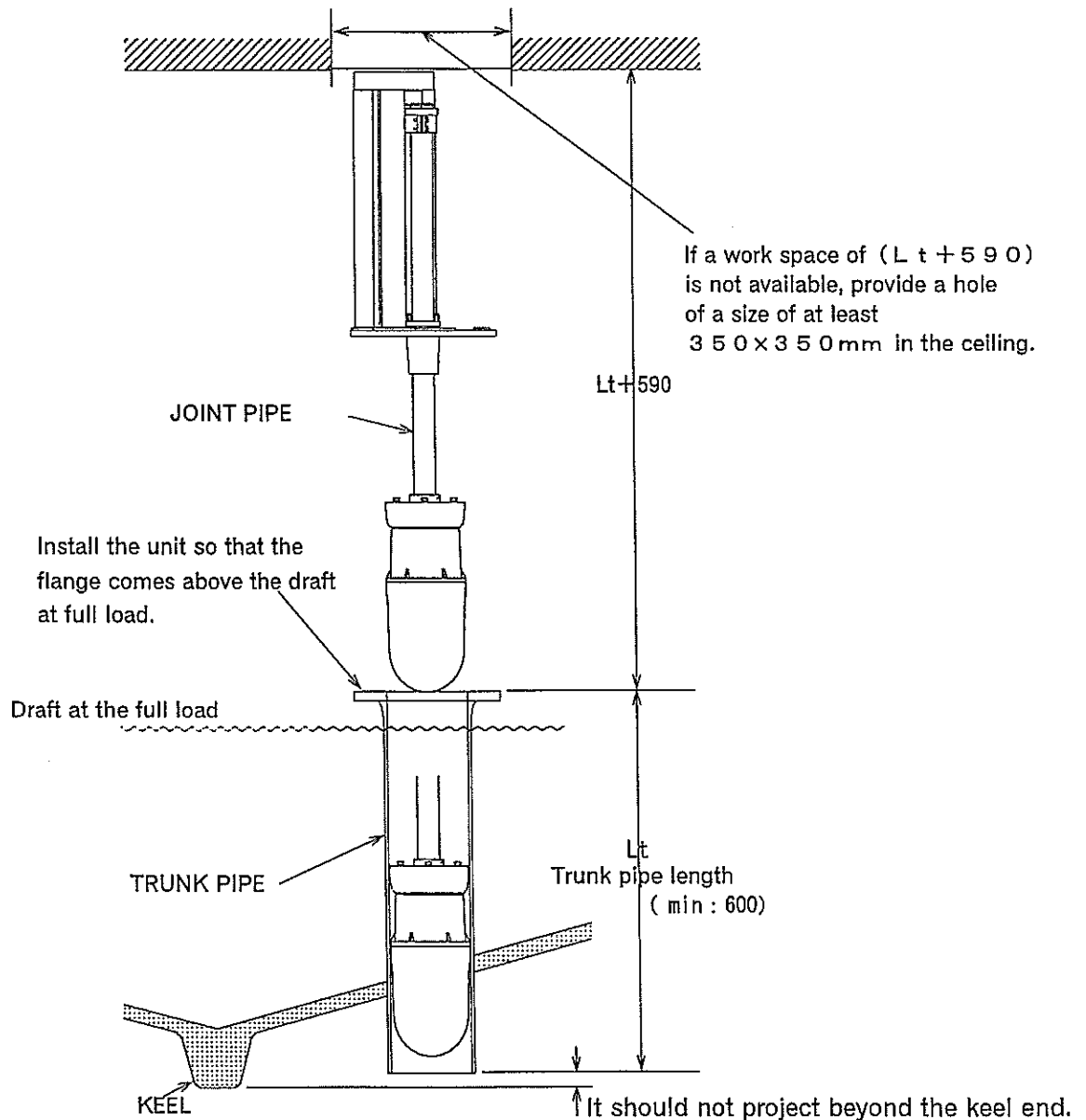

INSTALLATION

2 INSTALLATION CONDITIONS

© The Trunk Pipe should be installed satisfying the following conditions.

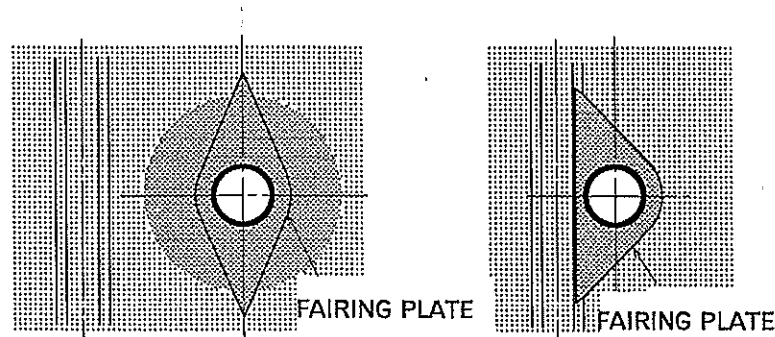
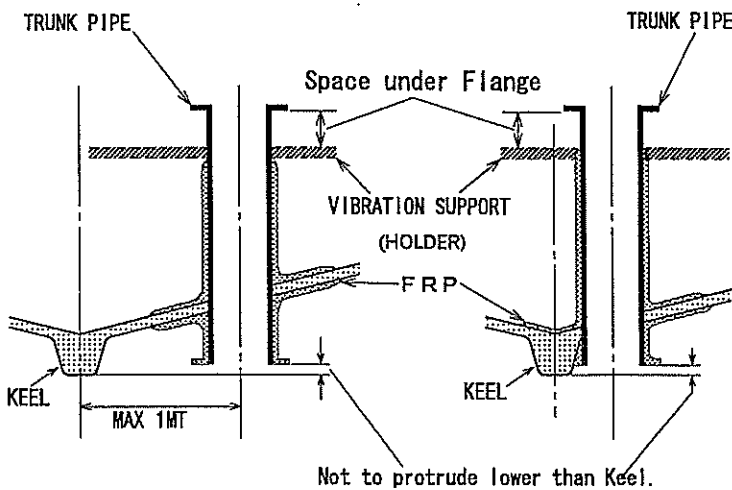
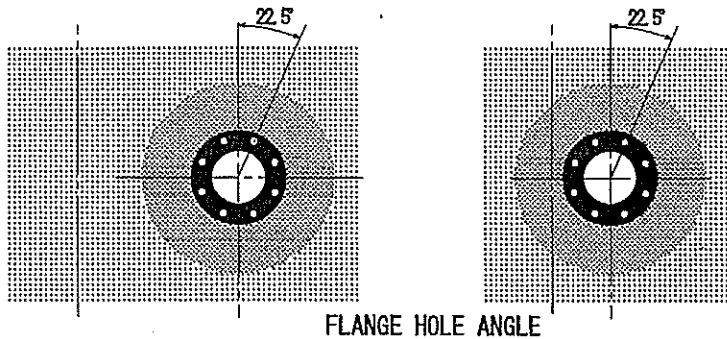

- The position for installation should be within $1/3$ to $1/2$ of the overall length from the bow.
- It also should come on the keel or within 1m for the keel.
- There should be no obstacles right below the flange of the tank which may interrupt bolt clamping of the flange.
- The top end of the pipe should not project below the keel end.
- The flange surface of the trunk pipe should stay level during standard cruise.
- Apply FRP sufficiently to all the necessary sections to prevent leakage of water.
- Make the surrounding of the pipe projecting out from the bottom in a streamline shape and provide a fairing plate to suppress water resistance and generation of air bubbles to the minimum.
- When necessary, install a holder to stop shaking. When doing this, make sure the holder does not interfere bolt clamping of the flange.



© Fully discuss about the strength and water tightness with the ship owner, persons in charge in the shipyard and the installer before determining on the position and the method of installation and necessary materials.

3 EXAMPLES OF INSTALLATION OF THE TRUNK PIPE

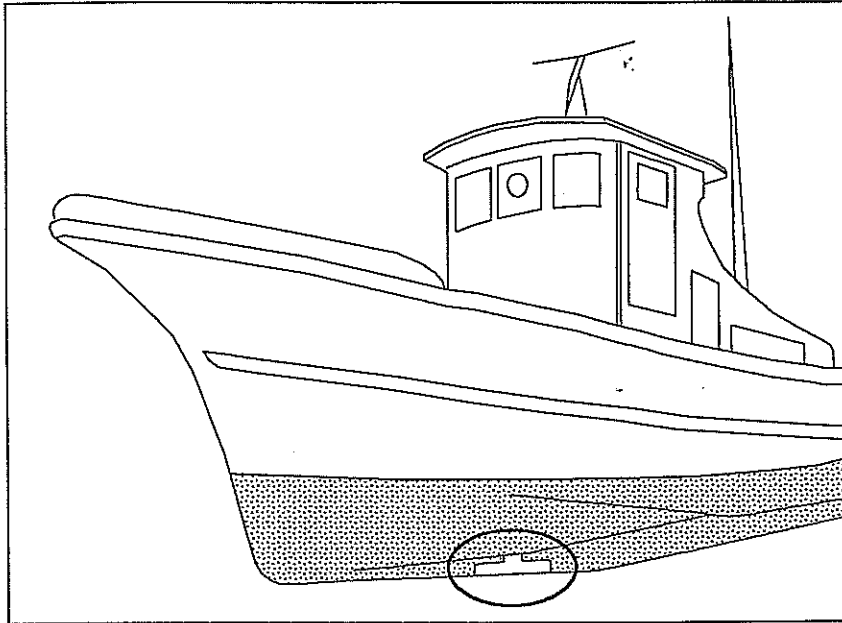

- The position to install the trunk pipe.
cf page 11

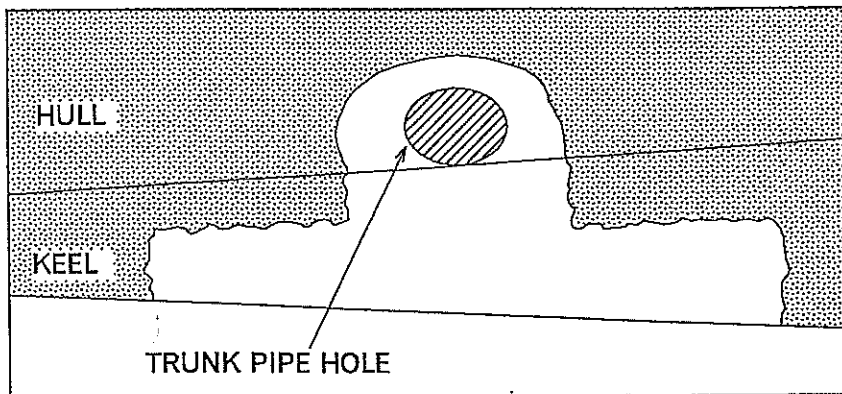

- Open a hole of the same diameter as of the trunk pipe along the keel in the bottom.

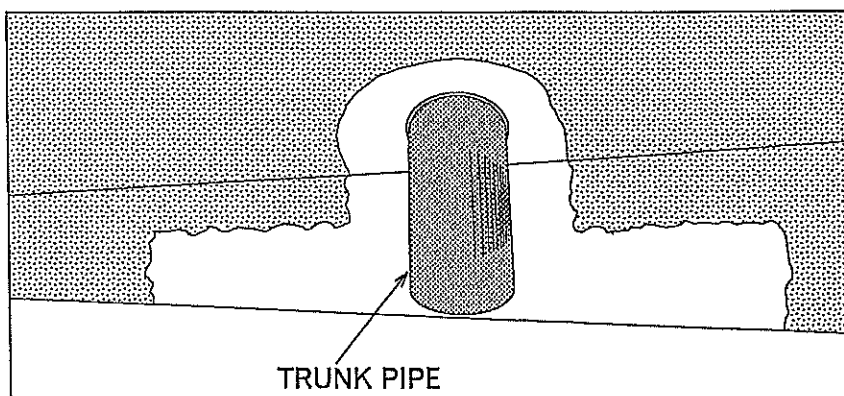

- Install the trunk pipe into the hole.
 The flange surface of the trunk pipe should stay level during standard cruise.

<to be continued>

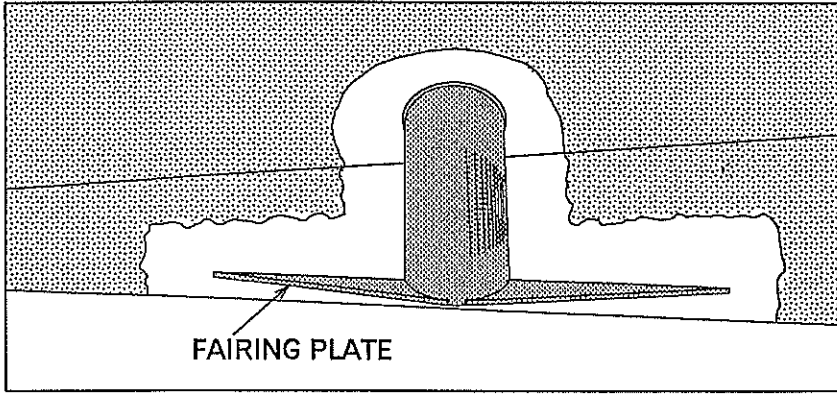

- Make the surrounding of the trunk pipe projecting out from the bottom in a streamline shape and provide a fairing plate to suppress water resistance and generation of air bubbles to the minimum.

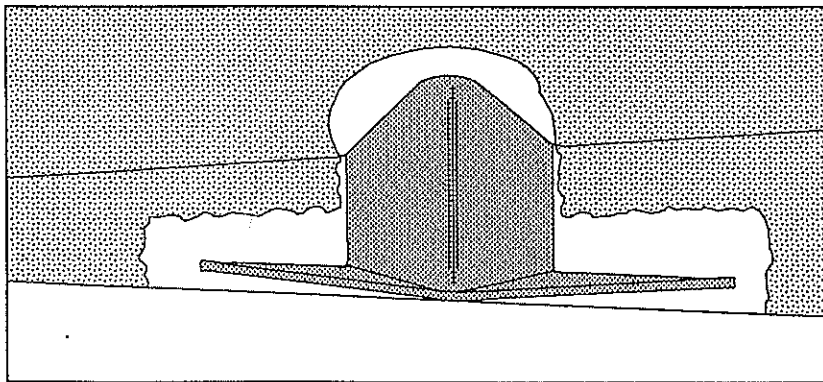
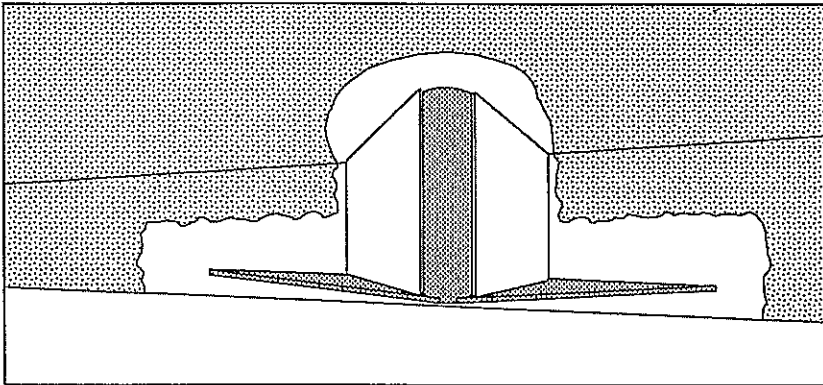

- Apply FRP sufficiently to all the necessary sections to prevent leakage of water.

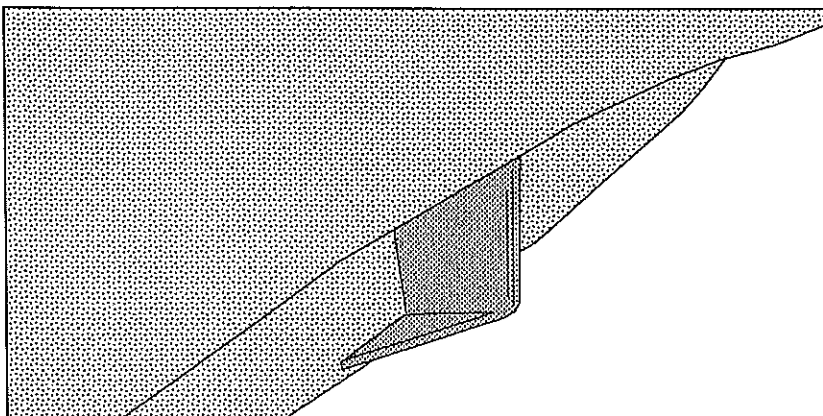

HULL UNIT ASSEMBLY (H180/80)

1 JOINT PIPE LENGTH

STANDARD JOINT PIPE LENGTH = TRUNK PIPE LENGTH + 181mm

If you need a joint pipe longer, consult us when placing your order.

2 JOINT PIPE ADJUSTMENT

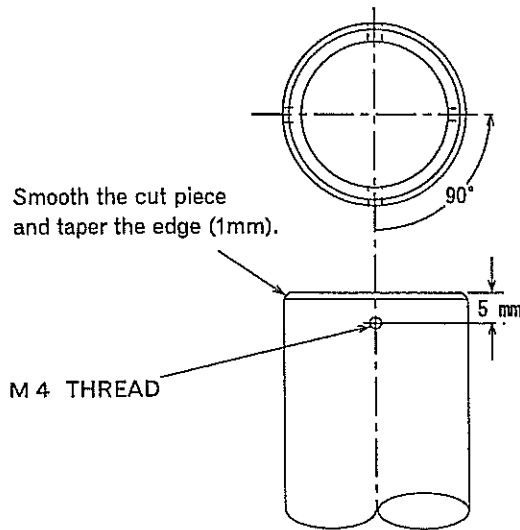

⊙ If the Joint Pipe length is standard i.e. Trunk Pipe + 181mm, adjustment is unnecessary.

- ① Cut the Joint Pipe to the required length.
- ② Smooth the cut piece and taper the edge as shown.
- ③ 5 mm from the end of the pipe and at an angle of 90° drill four ϕ 3.4 holes and tap with a M4 thread.

⊙ When using a short Trunk Pipe the Joint Pipe may be cut in the method explained above.

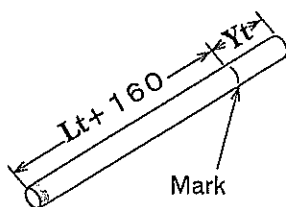

A mark is attached to the place of $Lt + 160$. This mark is united and bound tight at the upper end of Joint arm.

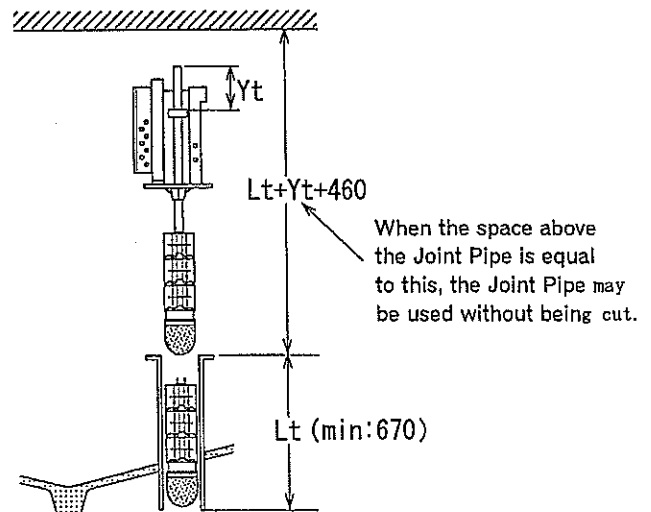

3 MOUNTING THE JOINT PIPE TO THE SOUNDOME

① Mounting the Joint Pipe to the Soundome

When attaching the Joint Pipe to the Soundome, be sure not to damage the Joint Pipe thread or twist the Soundome cable.

- Totally wipe dirt and grease off from the threaded parts of the Soundome and the Joint Pipe and apply sealing agent.
- Clamp the Joint Pipe into the Soundome as tight as possible and lock the clamp using M4x10 Cap bolts (4 units.) and cover up the Cap bolts by the sealing agent.
- Apply the bow mark at the top end of the Joint Pipe.

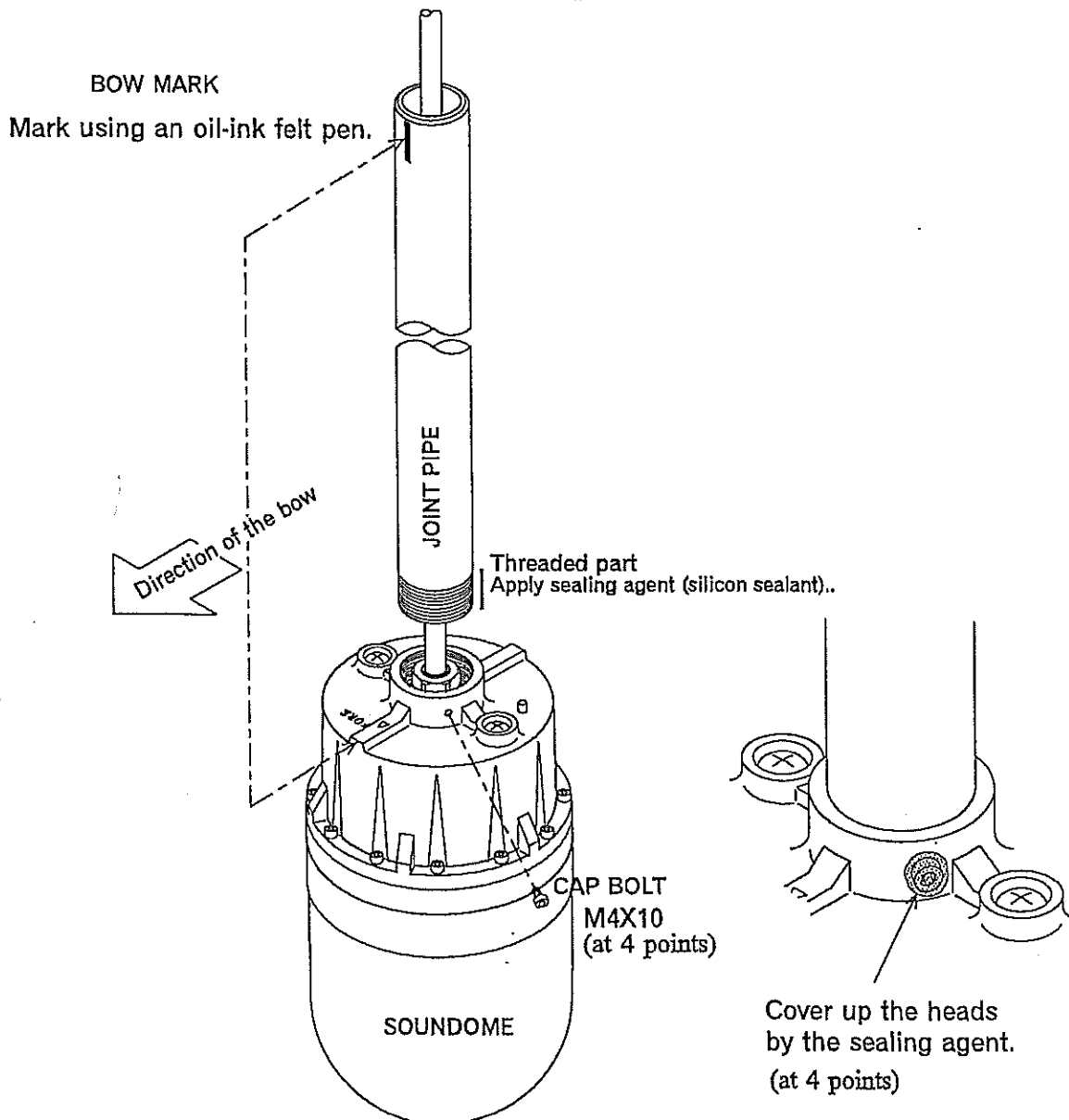

② Attaching the Pipe Guides

- Thread the three Pipe Guides onto the Joint Pipe in the direction shown below.
- Thread the fixing collar and tighten the attached cap bolts (4 pcs) .
- Thread the Fixing collar and tighten it using the attached cap bolts (4 pcs).so that the guides can not move

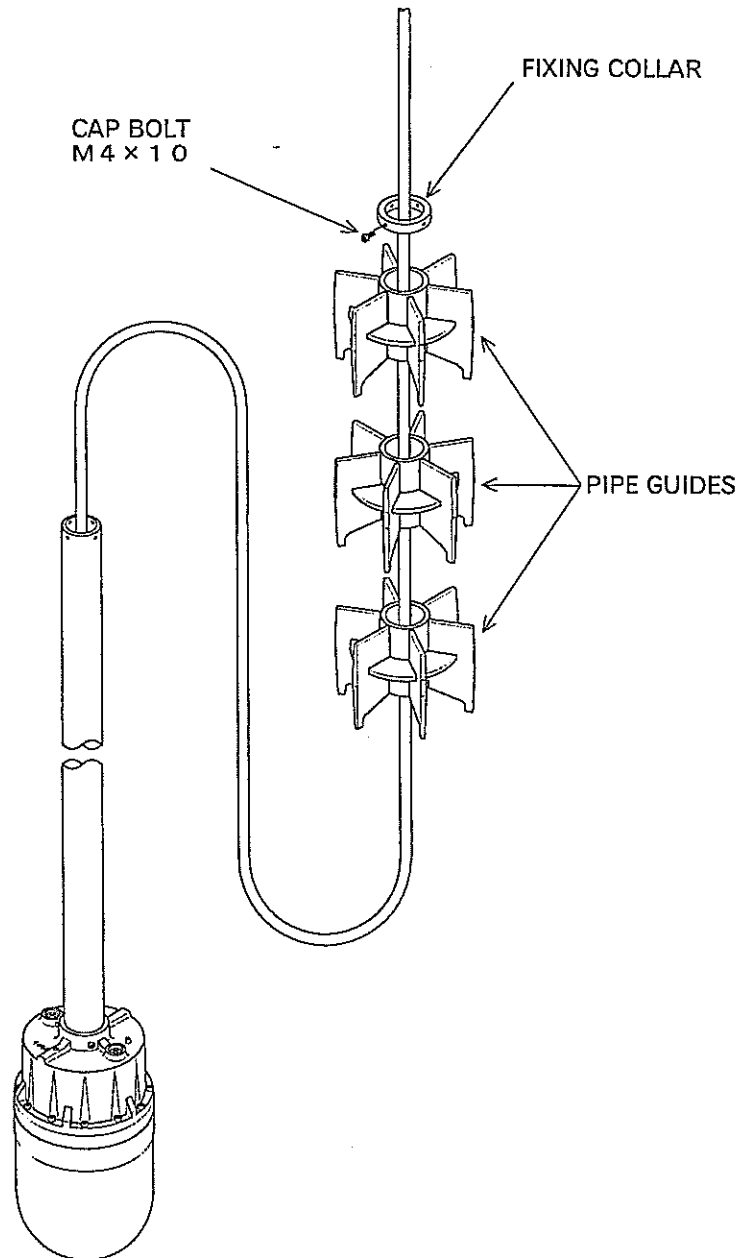

<To be continued>

INSTALLATION

③ Attaching the Soundome to the Hoist

- Apply grease to the bearing of the Flange.
- Loosen the water proof nut and thread the Joint pipe through the Flange bearing and thread the dumper. Mount them to the Joint arm matching the bow direction.
- Ensure that the Joint pipe end projects 30mm from the Joint arm surface.
In case of the length of the Trunk Pipe other than 1681mm long, ensure the lowest part of the Soundome is at least 50mm above the lowest part of the Trunk pipe.
- To prevent slip-out of the Joint pipe, fasten the attached Fixing collar using cap bolts (4 pcs).

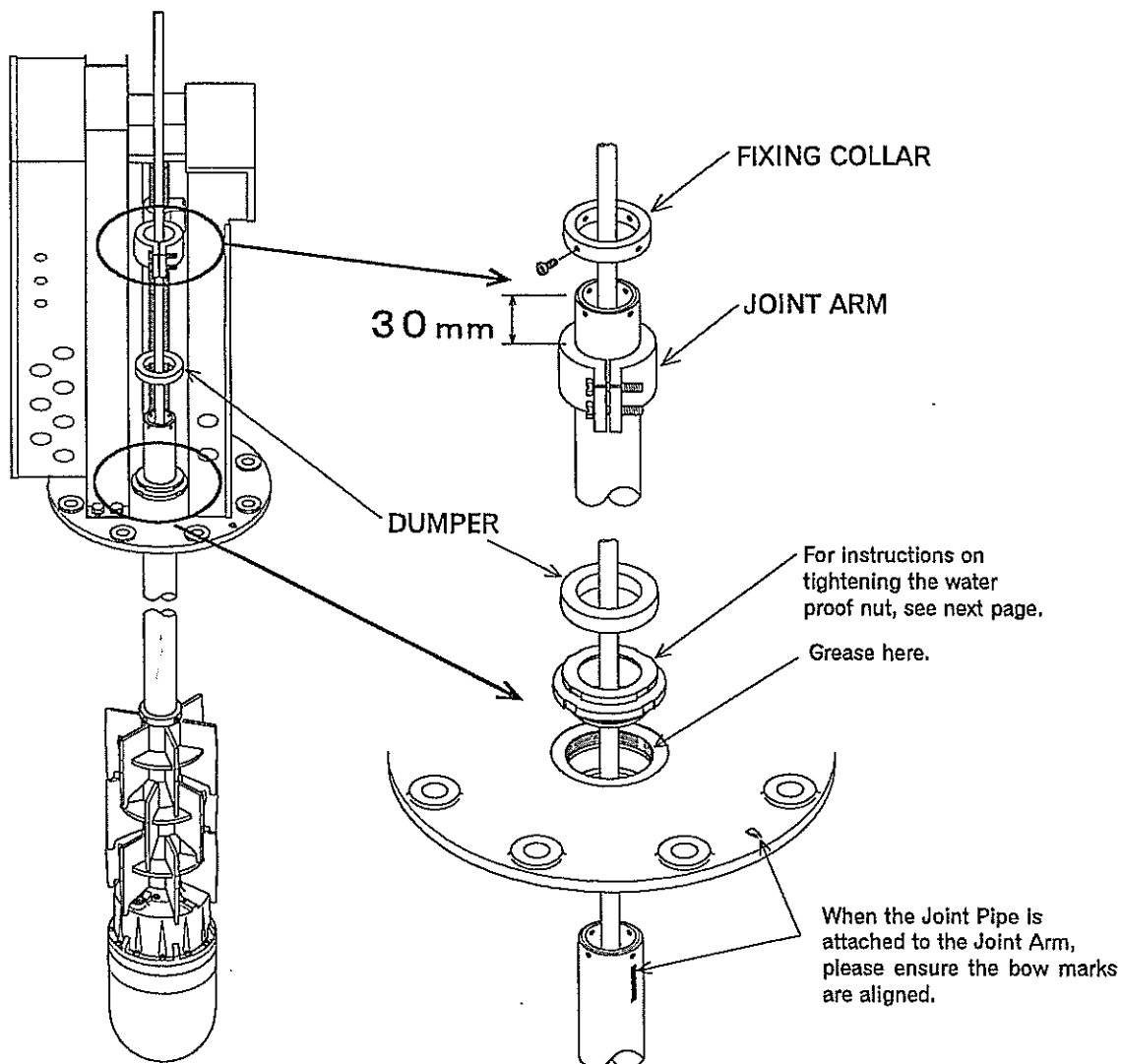

④ Attaching the Pipe Head to the end of the Joint Pipe

- Insert the Pipe Head into the end of the Joint Pipe as per the diagram below and tighten the attached cap bolts.
- To prevent slip-out of the pipe cap tighten the cap bolts, 4 pcs included as the accessories, (M4x10).

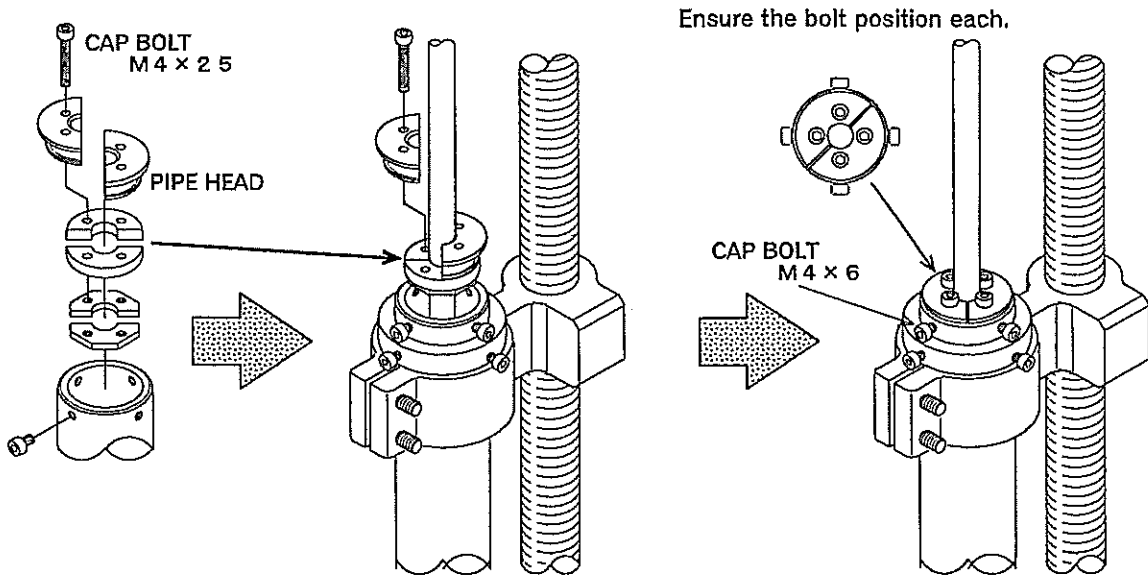

⑤ How to tighten Water Proof Nut and Locknut

- Lift up the Locknut as shown in the diagram below. Tighten the Water Proof Nut firmly by hand into the Flange opening. Turn the nut 180° with screwdriver and the hammer. Not to over tighten this nut.
- The Locknut is used to prevent slip-out of the Water Proof Nut.

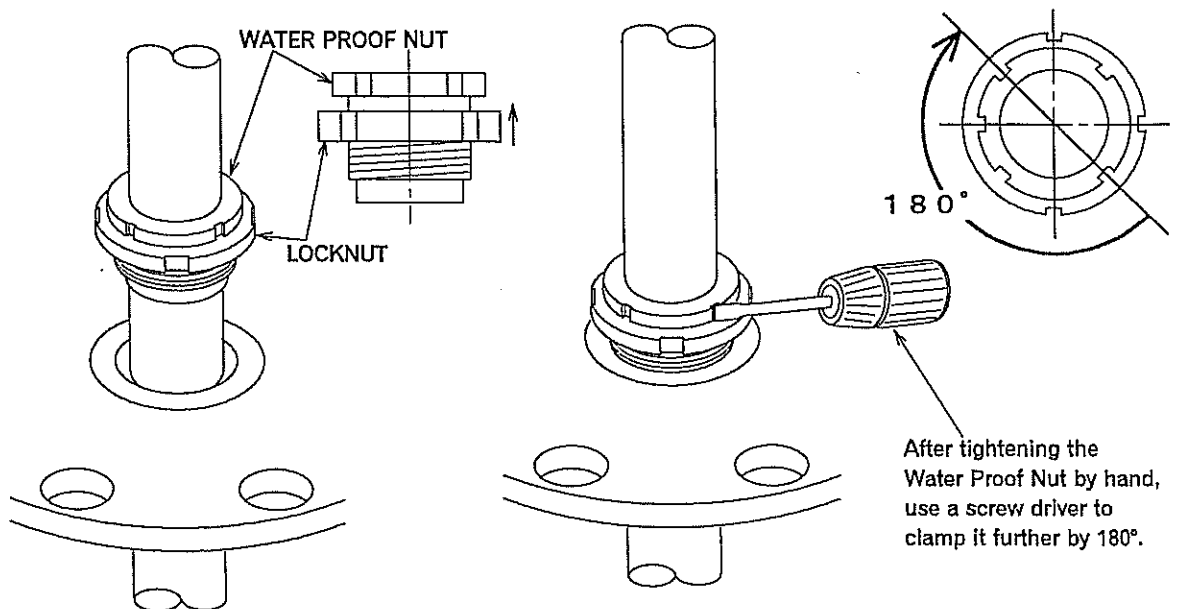

<to be continued>

INSTALLATION (H180/80)

⑥ Hull Unit and Trunk Pipe attachment.

- Use the 8 attached hexagonal bolts (M16 x 55) to fit the Hull unit to the Trunk pipe. When clamping bolts for fitting the Hull unit to the Trunk pipe, make tentative clamp and try to move the soundome up and down for several times to confirm the alignment when making the final clamping evenly.

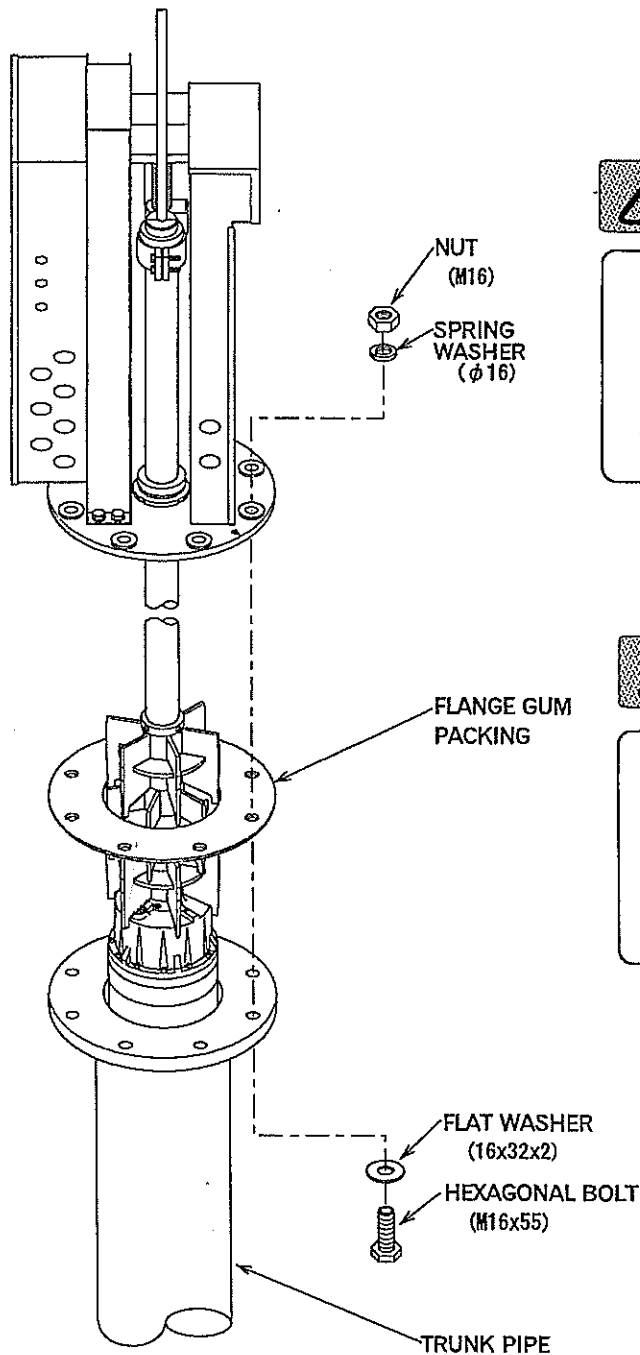

Please apply grease regularly to the Flange opening and Hoist gears.



Do not apply adhesive, etc. on the Gum packing of the Flange but use it direct as it is.

4 ADJUSTMENT OF THE HOIST STROKE

- ◎ The stroke from the trunk pipe of the soundome can be adjusted within the range of 200 to 400 mm. Adjustment of the stroke can be made by adjusting the lower limit switch of the hoist-lower unit.

If the limit switch is raised, please use the ANP base and plastic bands provided ensuring the limit switch wiring does not touch the Hoist gears.

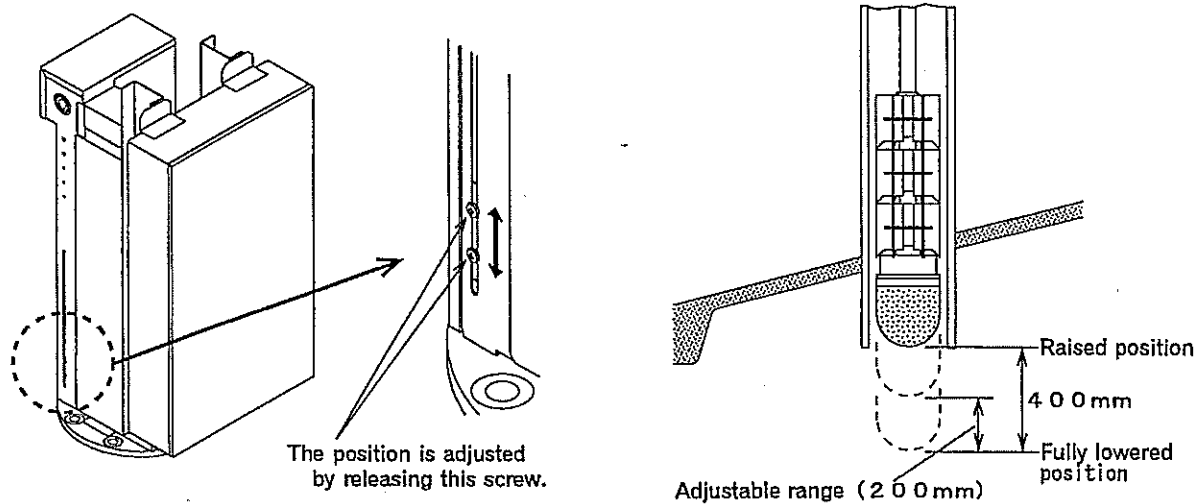

5 MANUAL OPERATION OF THE HOIST

- ◎ In the case the Hoist is unable to raise the Soundome, it can operate the Hoist manually as shown in the below drawings.

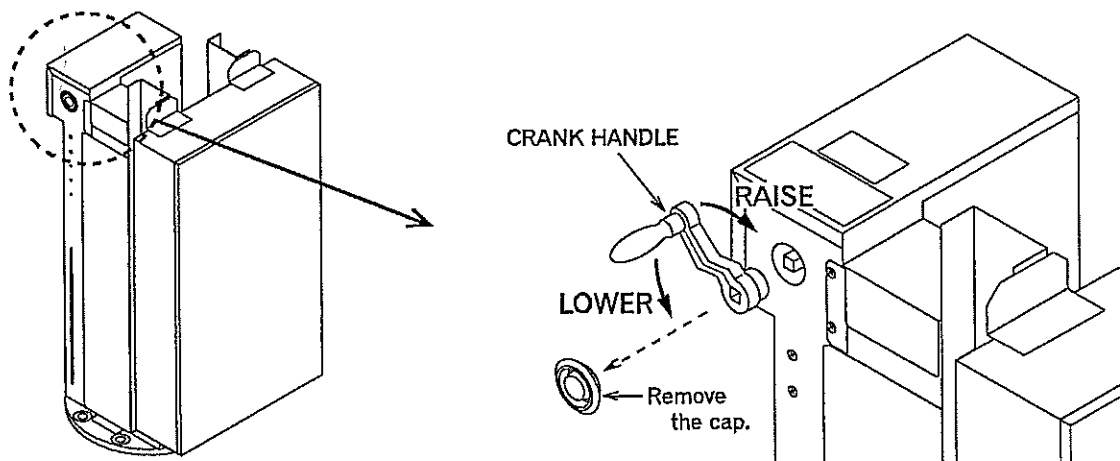

Confirm the voltage between the Flange and battery minus terminal does not exceed 0.65 volts after the assembly.
The damage to the soundome due to the corrosion may result, if the voltage exceeds.

INSTALLATION (H150)

HULL UNIT ASSEMBLY (H150)

1 JOINT PIPE LENGTH

$$\text{STANDARD JOINT PIPE LENGTH} = \text{TRUNK PIPE LENGTH} + 120\text{mm}$$

If you need a joint pipe longer, consult us when placing your order.

2 JOINT PIPE ADJUSTMENT

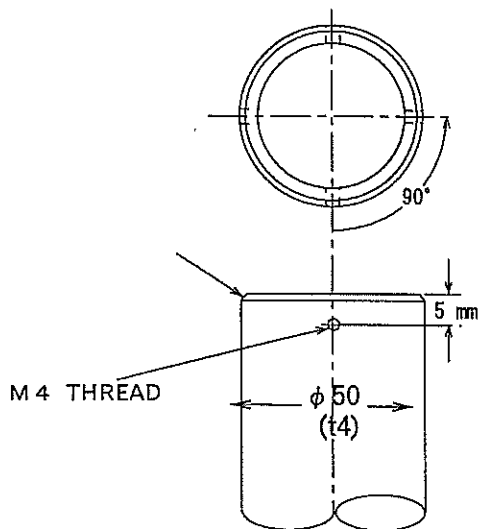

⊙ If the Joint Pipe length is standard ie. Trunk Pipe + 120mm, adjustment is unnecessary.

① Cut the Joint Pipe to the required length.

② Smooth the cut piece and taper the edge as shown.

③ 5 mm from the end of the pipe and at an angle of 90° drill four ϕ 3.4 holes and tap with a M4 thread.

• When using a short Trunk Pipe, the Joint Pipe may be cut in the method explained above.

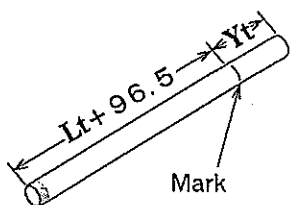

A mark is attached to the place of $Lt + 96.5$. This mark is united and bound tight at the upper end of Joint arm.

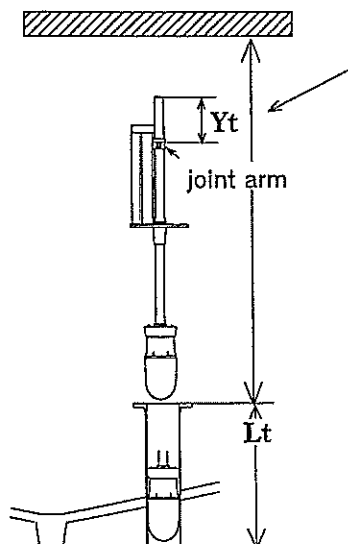

The following work space over the flange is required.

• In case Yt is less than 95.5

$$Lt + 590$$

• In case Yt is more than 95.5

$$Lt + Yt + 496.5$$

3 MOUNTING THE JOINT PIPE TO THE SOUNDOME

① Mounting the Joint Pipe to the Soundome

When attaching the Joint Pipe to the Soundome be sure not to damage the Joint Pipe thread or twist the Soundome cable.

- Totally wipe dirt and grease off from the threaded parts of the Soundome and the Joint Pipe and apply sealing agent.
- Clamp the Joint Pipe into the Soundome as tight as possible and lock the clamp using M4x10 Cap bolts (4 units.) and cover up the Cap bolts by the sealing agent.
- Apply the bow mark at the top end of the Joint Pipe.

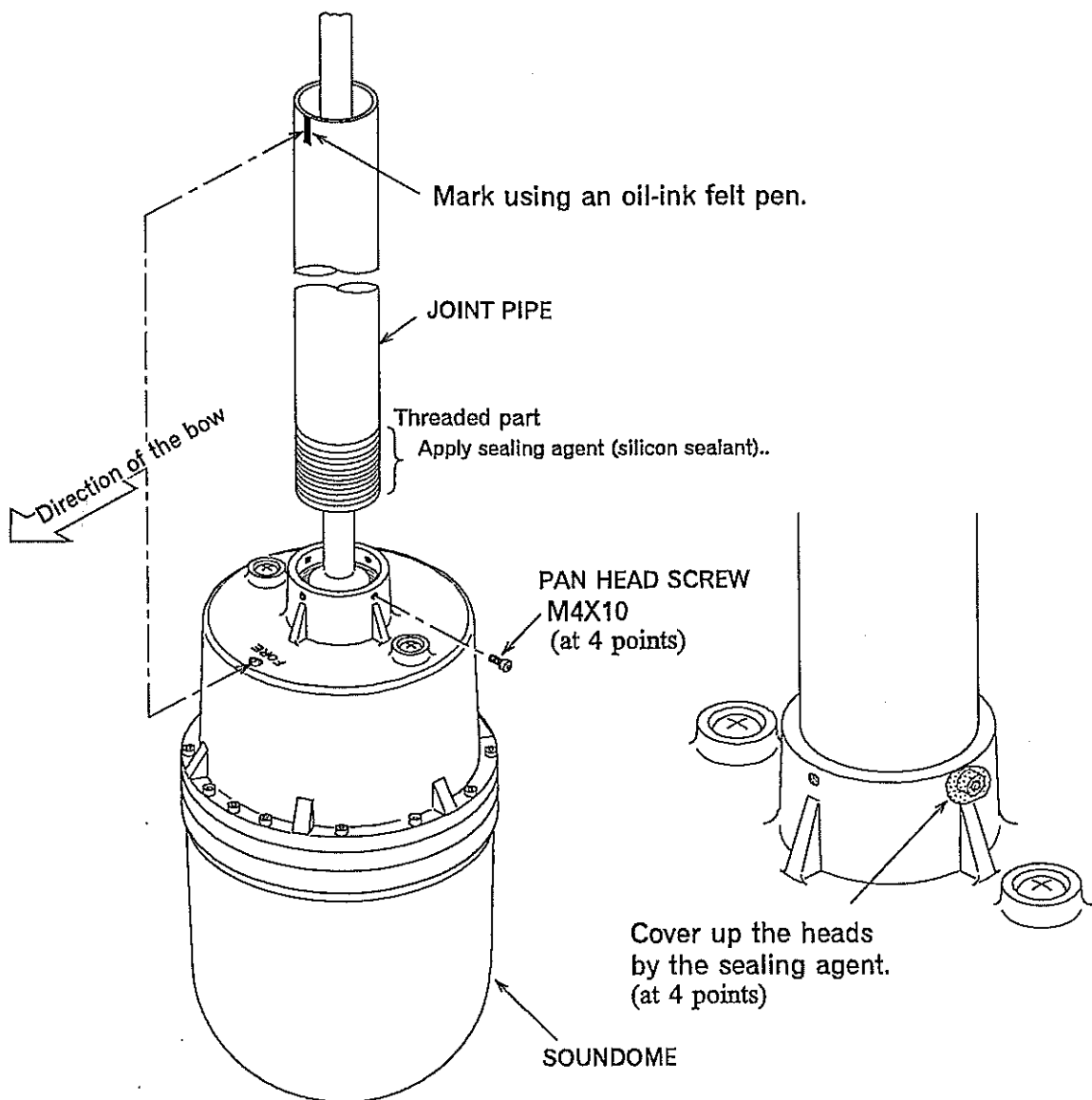

<To be continued>

INSTALLATION(H150)

② Attaching the Pipe Guide Assembly

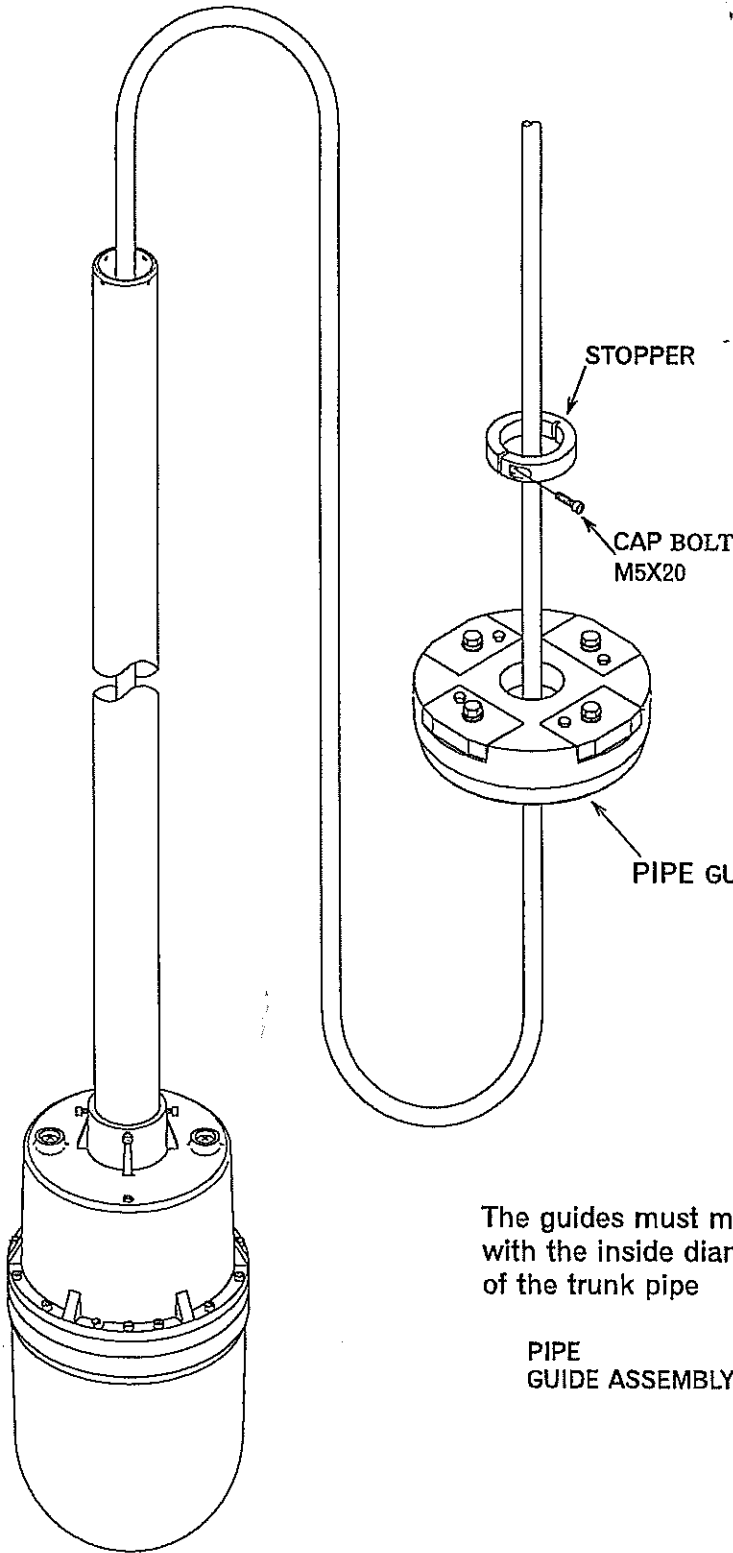

- Pipe guide should match with the inside diameter of the trunk pipe and tighten hexagonal bolts (M8). At this time the hole of the base should be centered in the trunk pipe.
- Make 4 holes on the Pipe guide base with the same diameter $\phi 5.5$ as of the pipe guide and tighten the attached hexagonal bolts (M8x35) and nuts.
- Pass the pipe guides through the pipe and fasten the pipe guide using the fixing collar. Use the pan head screw to fix the collar.

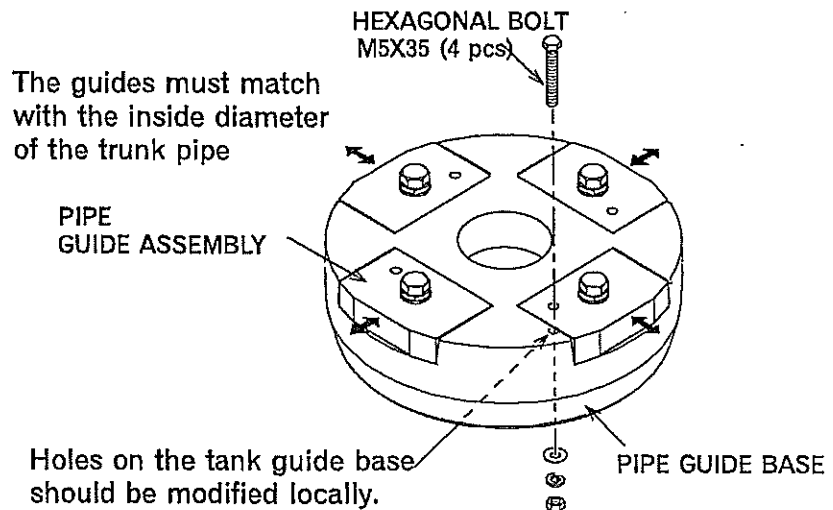

<To be continued>

INSTALLATION (H150)

③ Attaching the Soundome to the Hoist.

- Apply grease to the bearing of the Flange.
- Pass the Joint pipe through the Flange bearing and mount to the Joint arm matching the bow direction.
- When using the standard Joint pipe (standard length 1,350mm), adjust the the position of the Joint arm so that the Joint pipe end comes out by 25mm from the Joint arm surface.

When using any other type of Joint pipe, set the soundome to a position 35mm less of the overall length of the Trunk pipe.

- To prevent slip-out of the Joint pipe, fasten the Fixing collar using a pan head screw.

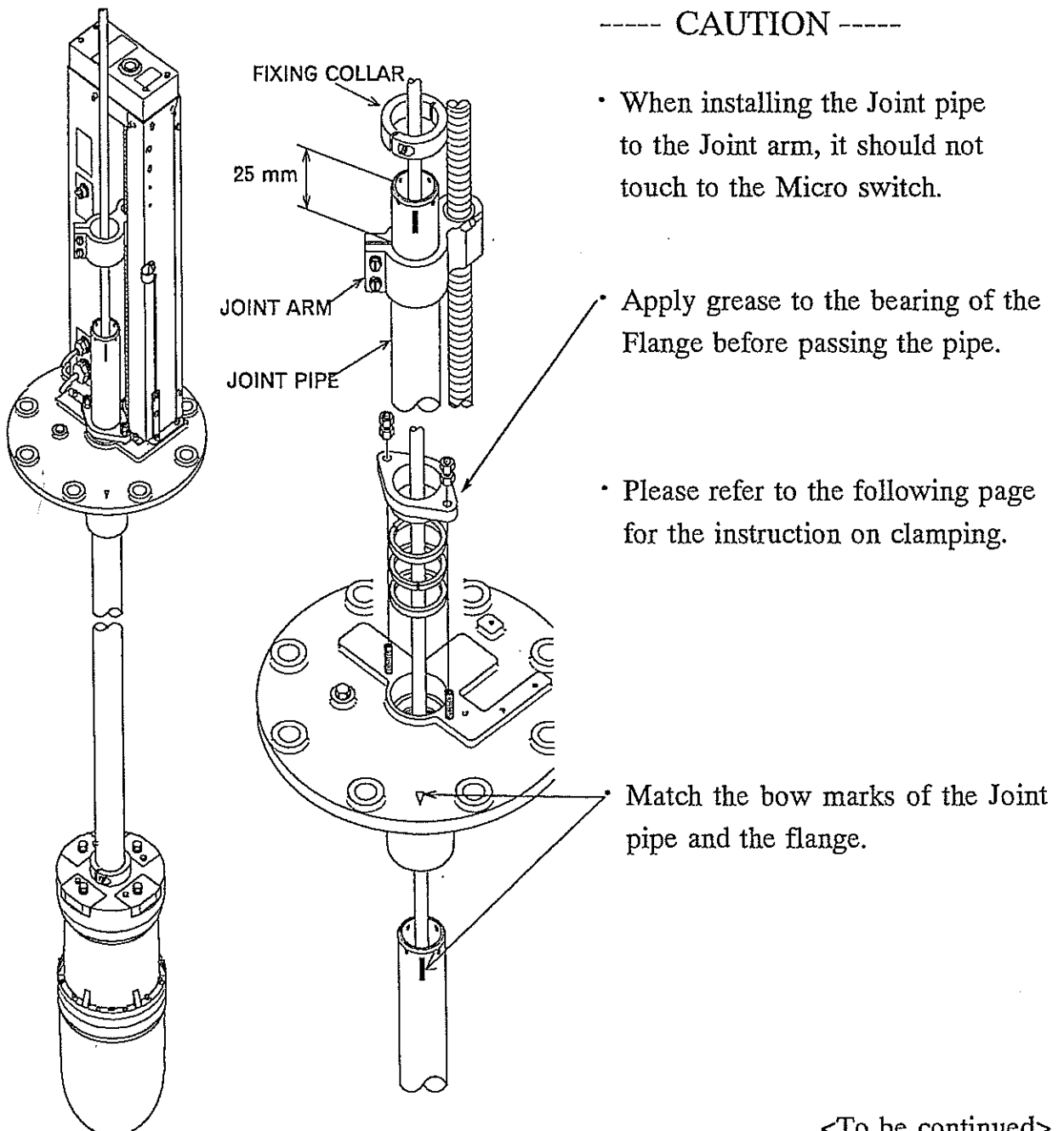

<To be continued>

INSTALLATION (H150)

④ Attaching the Pipe Head to the end of the Joint Pipe.

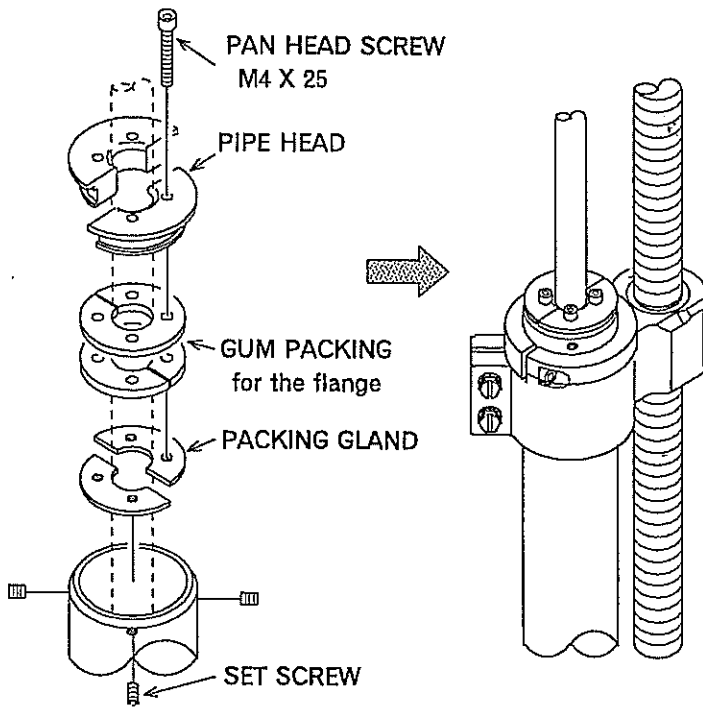

- Assemble the Pipe head onto the soundome cable as shown in the drawing left and make tentative clamp of the Pan head screw.
- Insert the Pipe head into the Joint pipe and clamp 4 pan head screws evenly.
- To fasten the Pipe head with the attached 4 set screws.

⑤ Adjusting the Water proofing nuts and Lock nuts

- Release the upper Lock nuts securing the Packing gland. Screw the down Lock nut to narrow the opening within 5mm, as shown in the drawing below, clamping the Lock nuts evenly.
- Put the released upper Lock nuts back and clamp again.
- In case of the water leakage after returning vessel to the water, the same procedure as described above is required again.

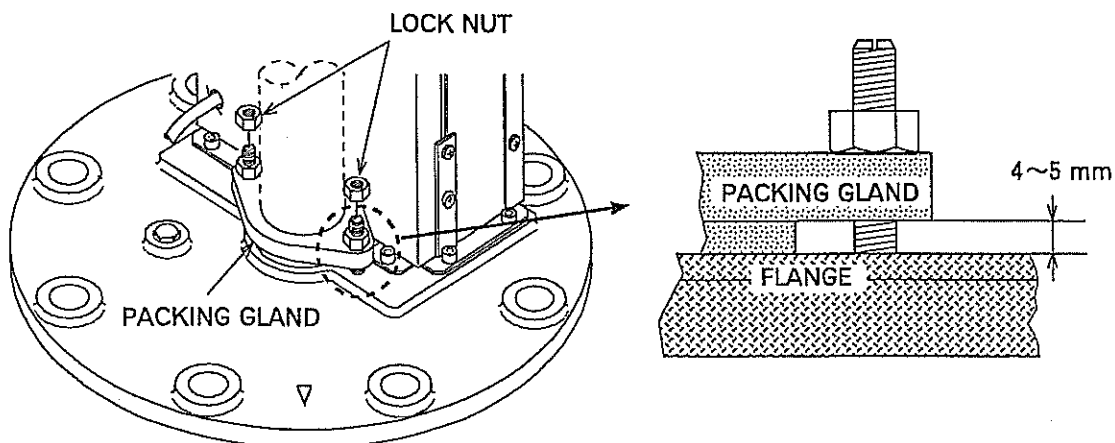

<To be continued>

⑥ Hull Unit and Trunk Pipe attachment.

- Use the 8 attached hexagonal bolts (M20 x 80) to fit the Hull unit to the Trunk pipe.
- When clamping bolts for fitting the Hull unit to the Trunk pipe, make tentative clamp and try to move the soundome up and down for several times to confirm the alignment when making the final clamping evenly.

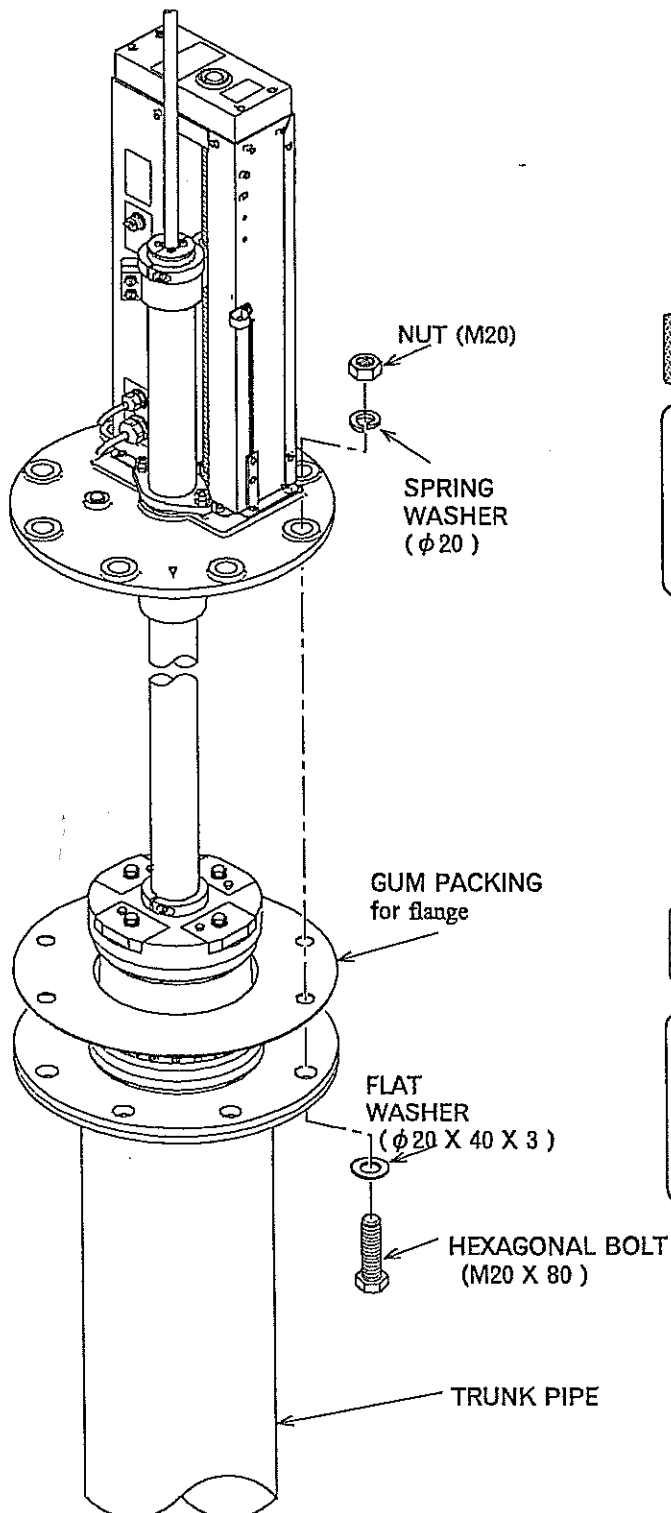

Please apply grease regularly to the Flange opening and Hoist gears.



Do not apply adhesive, etc. on the Gum packing of the Flange but use it direct as it is.

INSTALLATION (H150)

4 ADJUSTMENT OF THE HOIST STROKE

- ◎ The stroke from the trunk pipe of the soundome can be adjusted within the range of 200 to 400 mm. Adjustment of the stroke can be made by adjusting the lower limit switch of the hoist-lower unit.

If the limit switch is raised, please use the ANP base and plastic bands provided ensuring the limit switch wiring does not touch the Hoist gears.

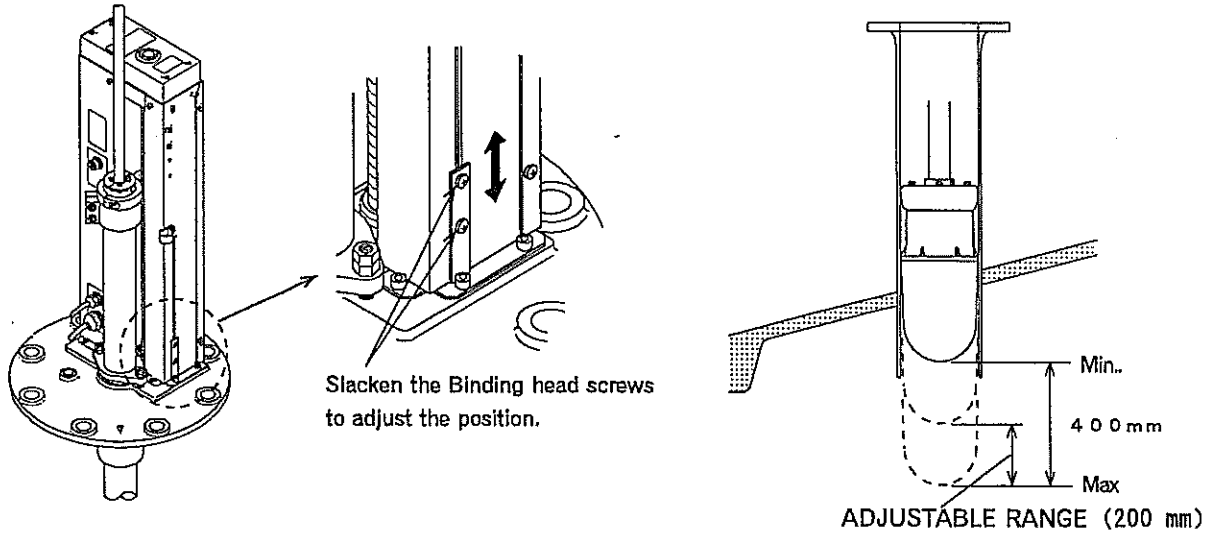

5 MANUAL OPERATION OF THE HOIST

- ◎ In the case the Hoist is unable to raise the Soundome, it can operate the Hoist manually as shown in the below drawings.
 - On using the crank handle to raise or lower the Hoist, make sure to turn off power (push down the switch for the motor). Otherwise it will cause trouble that motor runs and the handle reverses.

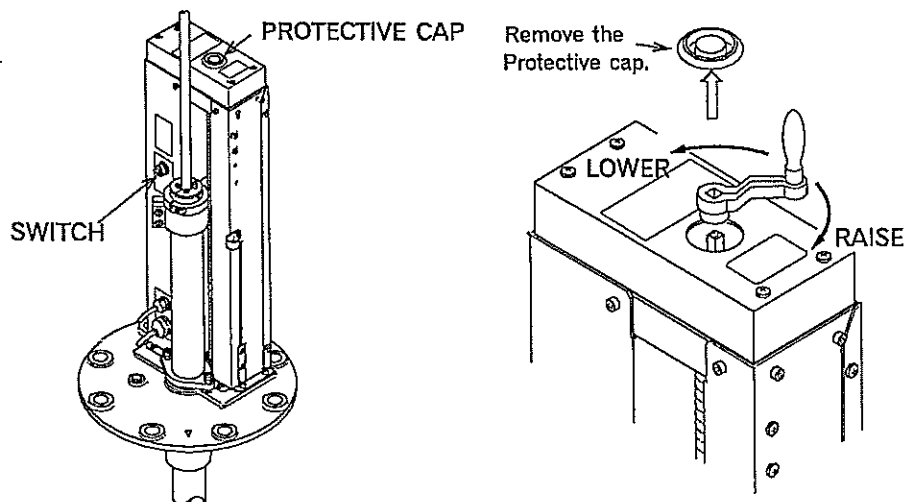

CONTROL UNIT INSTALLATION

- ◎ The Control unit may be installed in a location away from salt spray, heat sources and shocks. Allow enough service clearance.

Please check that the cable junction face should be at the bottom side or the right side.

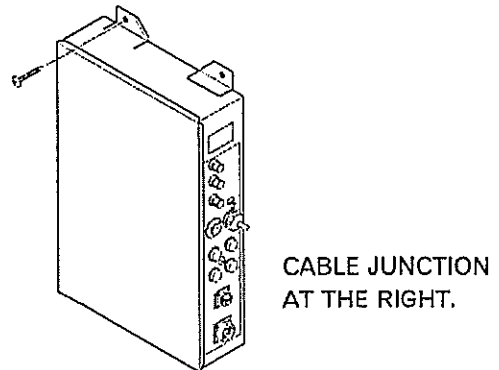
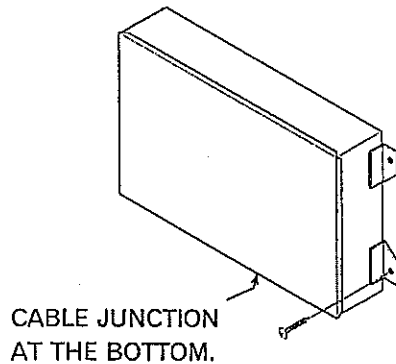

- ◎ After installing the Control unit, coil the self bonding tape around the junction of connectors and secondly coil the PVC tape around the self bonding tape for waterproofing on connecting the Hull unit and the Display unit.

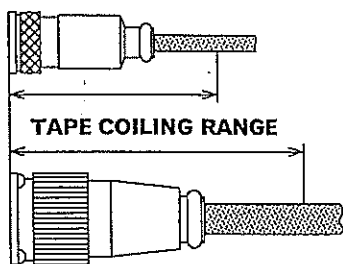

- ◎ Sealing Method for Self bonding tape

- ① Totally wipe dirt and grease off from the parts.
- ② Coil the self bonding tape to connector with three stratum, stretching the tape as it is double length.
- ③ After coiling, make a quick bonding by pressure of fingers.
- ④ Coil the PVC tape around the self bonding tape.

CONTROL UNIT CONNECTIONS **CF** page 37

INTERNAL CONNECTIONS **CF** page 41

INSTALLATION

DISPLAY CABINET INSTALLATION

- ① Using the attached tapping screws (6 pcs), secure the mounting plate to the site selected.
- ② Adjust the truss screws (2 pcs) to keep the best angle of the cabinet.
- ③ Insert the cabinet with the bracket into the gutter of the mounting plate. Tighten 2 hexagonal bolts at the notches.

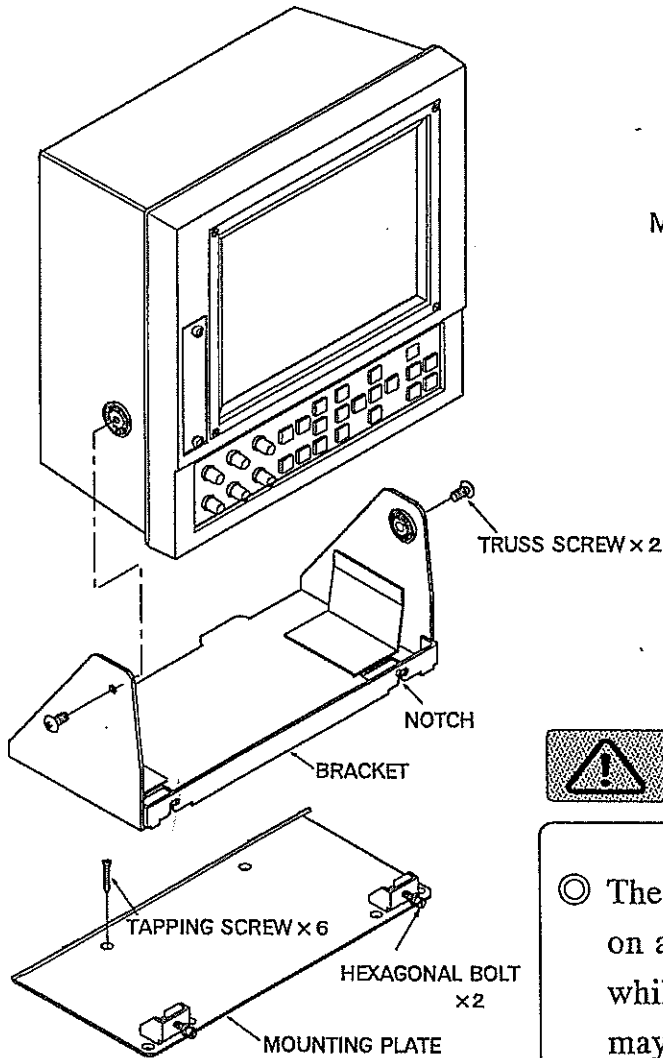

MAIN CABINET with ACCESSORIES

DISPLAY CABINET.....	1
BRACKET.....	1
MOUNTING PLATE.....	1
TRUSS SCREW (M8-15).....	2
TAPPING SCREW (M5-30).....	6
HEXAGONAL BOLT(M6-20).....	2



⊙ The Display cabinet should be installed on a flat surface. Do not use the unit while tentatively installed, otherwise it may cause trouble.



- ⊙ Make sure the unit is not close to any inverters, converters, or transformers that interfere with the sonar performance.
- ⊙ Install the unit in a location away from salt spray, heat sources and direct sunlight.

REAR PANEL CONNECTIONS

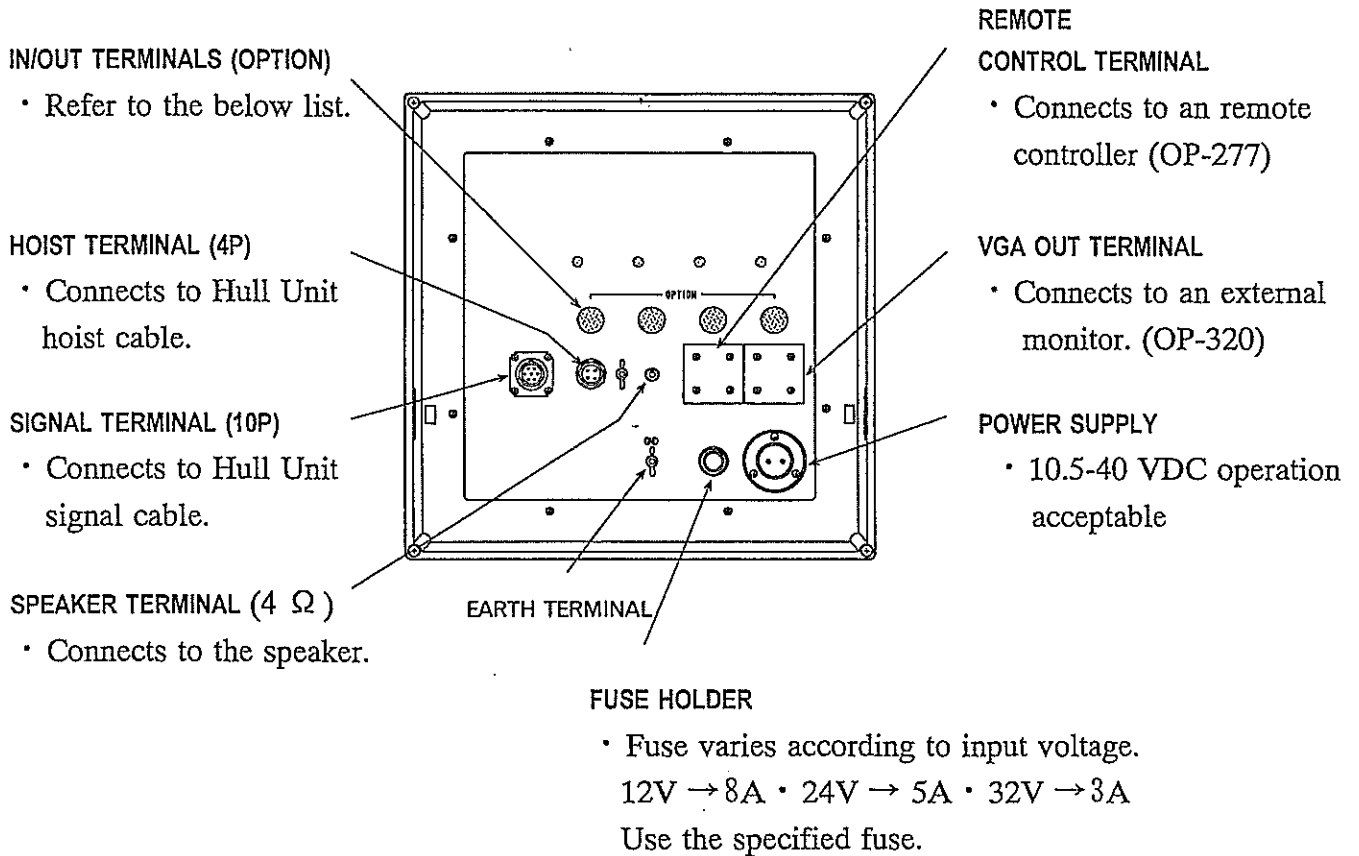

© AVAILABLE OPTIONAL CABLE KITS

PART NAME	FUNCTION	NOTES
OP-277	REMOTE CONTROL TERMINAL	• Connects to a remote controller
OP-305	NAV-IN TERMINAL	• Connects to an external navigator or reads NMEA-0183 sentences
OP-320	VGA TERMINAL	• Connects to an external monitor.
OP-322	TRIGGER TERMINAL	• To synchronize with an external sounder
OP-326	NMEA OUT	• Transmits the present target position LAT/LON coordinates

The details of the optional kits in the above list are shown at page 96/97.

INSTALLATION

NAMES & FUNCTIONS OF H180/80 HULL CONTROL UNIT

CABLE CONNECTION

FUSE 1 • 2 • 3

Please use fuses in accordance with the chart below.

FUSE 1	For Control Unit
FUSE 2	For Hoist Motor
FUSE 3	For Limit Sitch Circuit

When changing the fuses, please ensure the correct fuses shown in the fuse list are used.

FUSE SEAL

This shows the correct amperage.

VOLTAGE	12 V	24 V
FUSE 1	10 AMP	6 AMP
FUSE 2	5 AMP	8 AMP
FUSE 3	0.5 AMP	

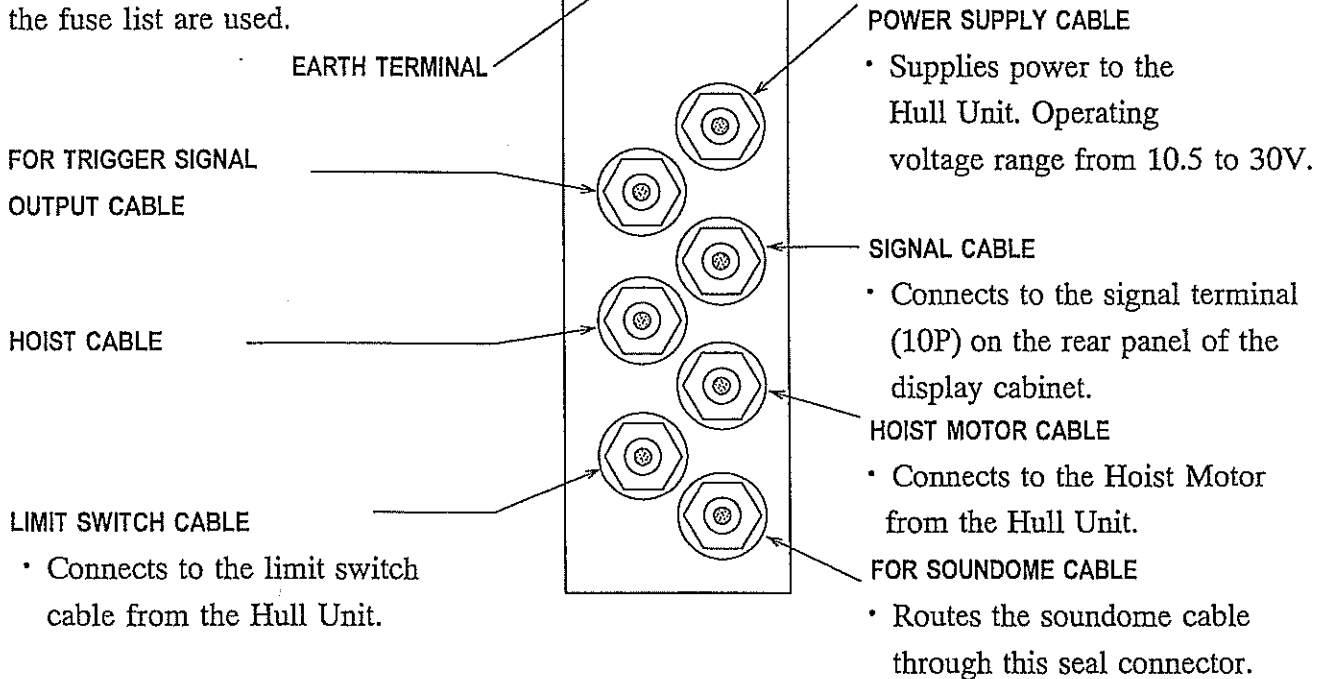

NAMES & FUNCTIONS OF H180/80 HOIST SYSTEM

CABLE CONNECTION

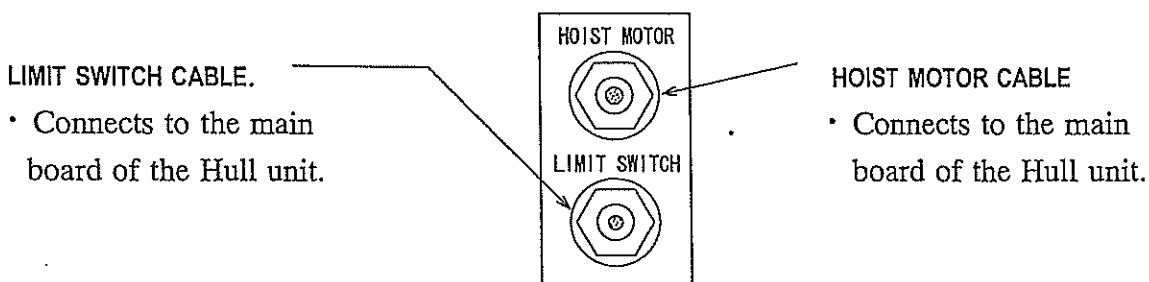

NAMES & FUNCTIONS OF H150 CONTROL UNIT PANEL

FUSE 1 • 2 • 3

Please use fuses in accordance with the chart below.

FUSE 1	For Limit Sitch Circuit
FUSE 2	For Control Unit
FUSE 3	For Hoist Motor

When changing the fuses, please ensure the correct fuses are used.

HOIST MOTOR CABLE

- Connects to the Hoist motor cable from the Hull Unit Panel.

HOIST TERMINAL (4P)

- Connects to the cable from the rear panel of the display cabinet.

NO CONNECTION

- Do not connect anything.

SOUNDOME TERMINAL (32P)

- Connection to the Soundome cable.

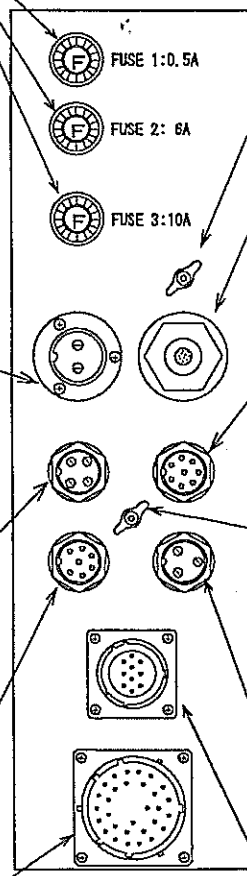

EARTH TERMINAL

POWER SUPPLY CABLE

- Supplies power to the Hull Unit
- Operates over the power supply voltage range from 20 to 30V

LIMIT SWITCH TERMINAL (8P)

- Connects to the 8P Limit switch cable from the Hull Unit Panel..

EARTH TERMINAL

- Connects to the Hoist cable earth terminal

TRIGGER SIGNAL OUTPUT (3P)

SIGNAL TERMINAL (10P)

- Connection to the cable from the 10P Signal terminal on the the rear panel of the display cabinet.

NAMES & FUNCTIONS OF OF H15 HOIST SYSTEM CABLE CONNECTION

LIMIT SWITCH TERMINAL

- Connects to the 8P Limit switch terminal on the Control Unit Panel.

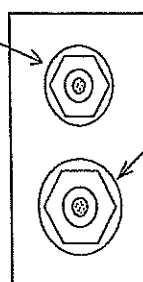

HOIST MOTOR CABLE

- Connects to the Hoist motor cable on the Control Unit Panel.

INSTALLATION

CONNECTIONS

- ◎ Prior to the connections between the display cabinet and the hull unit, read the following cautions carefully to ensure its correct operation.



- ◎ All S-1800 operate a universal power supply of the following voltages.

S-1800 M10 DISPLAY CABINET	: 10.5 ~ 40 V
S-1800 H180/80 HULL UNIT	: 10.5 ~ 30 V
S-1800 H150 HULL UNIT	: 20.0 ~ 30 V

Incorrect voltage may cause units damage.

- ◎ Please use the specified power supply cables.
If not, it may cause fire or any damage.
- ◎ Please check if the power from the flange to the battery (negative terminal) should stay within 0.65V. In case the higher voltage, connect with the thick cable and stay within 0.65V. Otherwise it may cause soundome damage.
- ◎ When connecting the cables, do not bent it to an acute angle, twist it, or impart excessive force because this sometimes causes cracks or damage.

CONNECTIONS FOR H180/80 **CF** page 39
CONNECTIONS FOR H150 **CF** page 41

CONNECTIONS of H180/80

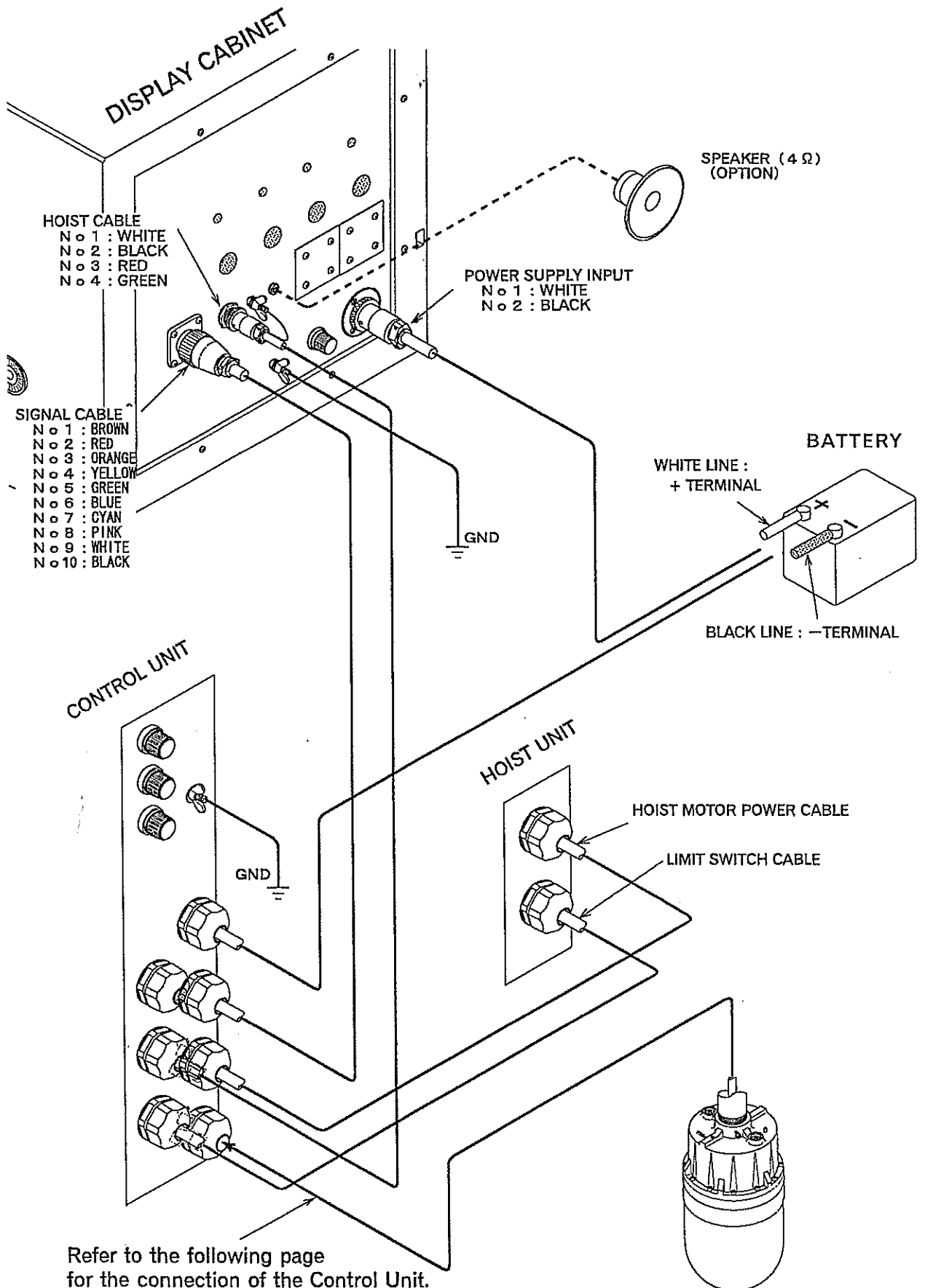

INSTALLATION

SOUNDOME WIRING

- Remove the cover of the Control unit and connects in accordance with the following notes and drawings.

CONTROL UNIT CONNECTING PARTS

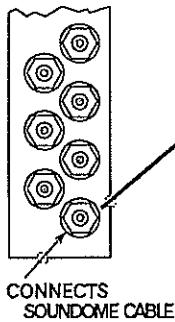

CABLE GLAND

CAP

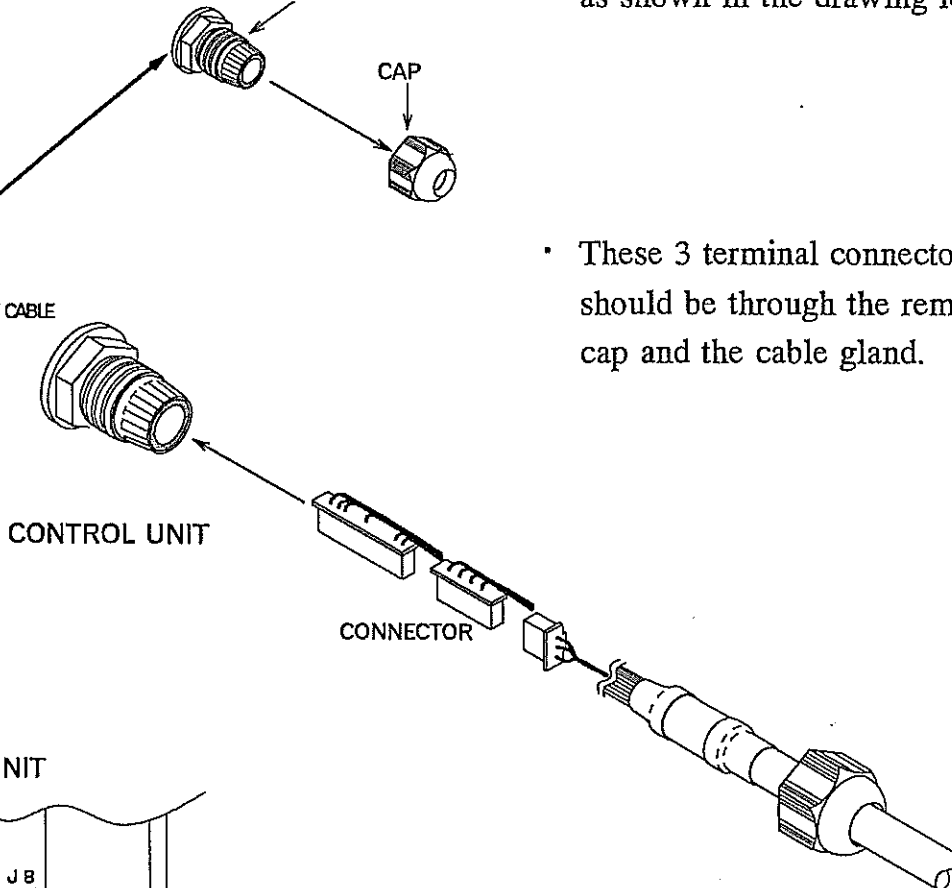

- Remove the cap of the seal connector from the cable gland as shown in the drawing left
- These 3 terminal connectors should be through the removed cap and the cable gland.

CONTROL UNIT

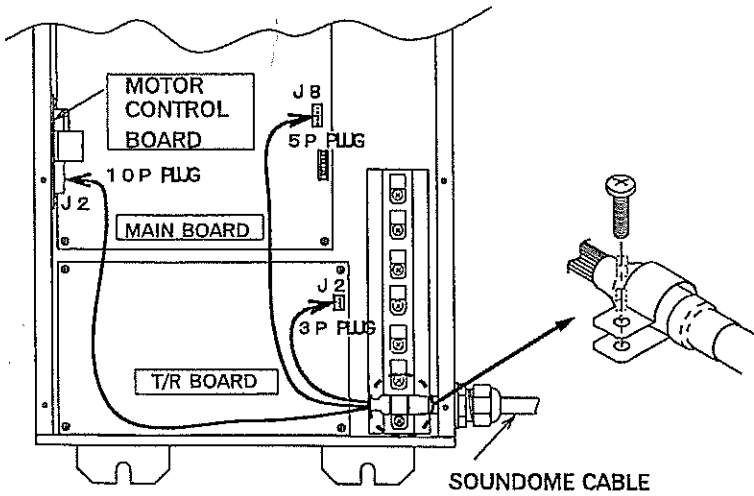

- As shown in the drawing left wind the metal band around the cable (GND) in the Control unit and tighten the screw.

- Connect the 3P plug to J2 on the T/R board, 5P plug to J8 on the Main board and 10P plug to J2 on the Motor Control board.
- Put the cover back to the unit after the connections are completed.

CONNECTIONS of H150

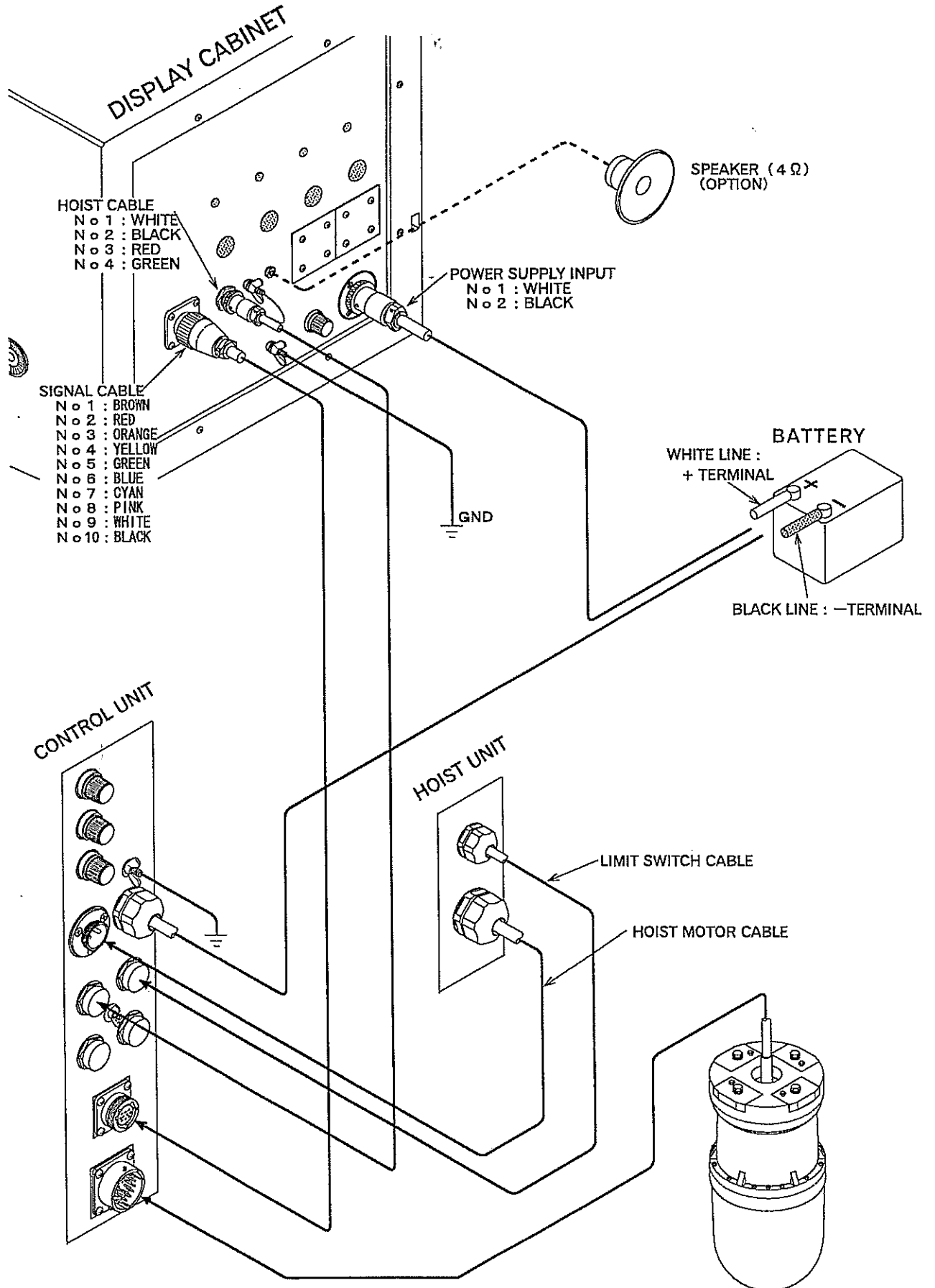

FUNDAMENTALS

This chapter explains the fundamentals of S-1800 systems.

FUNDAMENTALS

KEY FUNCTIONS	43
SCREEN DISPLAY	44
SONAR MODE DISPLAY	45
SONAR MODE OPERATION	46
BOTTOM SCAN MODE DISPLAY	49
BOTTOM SCAN MODE DISPLAY OPERATION ---	50
SOUNDER MODE	51
SOUNDER MODE OPERATION	52

FUNDAMENTALS

KEY FUNCTIONS

HOIST DOWN LIGHT: **CF** PAGE 88

- When the Hoist Down Light is on, it indicates that the soundome is in the down position.

CURSOR SHIFT KEYS (↑ ↓ ← →): **CF** PAGE 91

- Moves cursor or selects to display Marker or Cursor.

TARGET LOCK KEY: **CF** PAGE 93

- Turns on or off the target lock mode.

TILT KEY: **CF** PAGE 90

- Adjusts tilt angel.

BEARING KEY: **CF** PAGE 89

- Moves cursor center right or left.

RANGE DIAL: **CF** PAGE 85

- Selets a desired range scale

SECTOR DIAL: **CF** PAGE 86

- Adjusts the sector angel.

MODE DIAL: **CF** PAGE 85

- Changes Display Mode.

POWER ON/OFF KEY: **CF** PAGE 88

- Turns on/off the power.

HOIST KEYS: **CF** PAGE 88

- Uploads/downloads the soundome.

CURSOR SELECTION KEY

: **CF** PAGE 91

- Selects Ring Marker or Cross Marker.

MARK KEY: **CF** PAGE 94

THRESHOLD KEY: **CF** PAGE 94

- Reduces the unnecessary weak echoes accordingly.

OPERATION MODE: **CF** PAGE 95

- Calls up the user-defined setting or changes the settings.

FAR GAIN DIAL: **CF** PAGE 87

- Adjusts the receiver sensitivity for the long ranges.

GAIN DIAL: **CF** PAGE 87

- Adjusts the receiver sensitivity.

BRIGHTNESS DIAL: **CF** PAGE 87

- Adjusts the screen brightness.

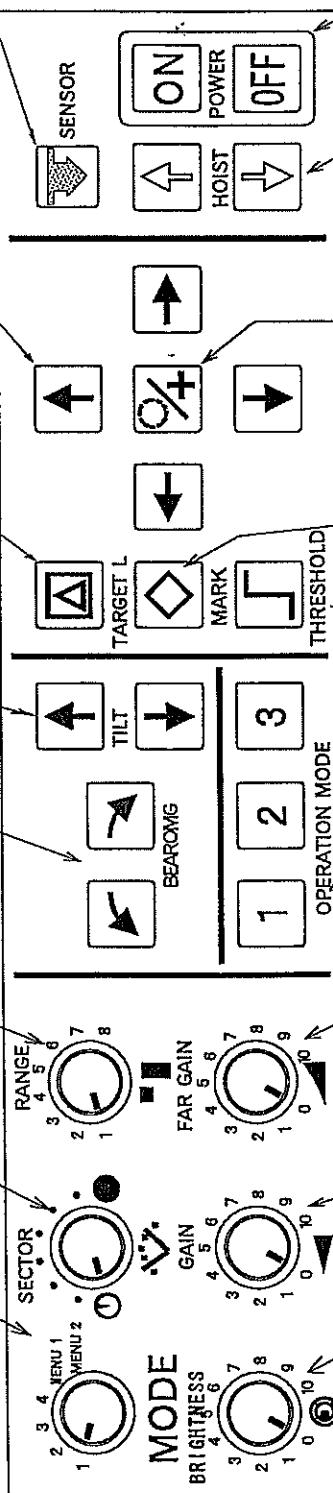

⊙ Make sure to turn on/off the power by turning the POWER ON/OFF KEY
Turning on/off the power by the switchboard may cause a serious problem
or wrong operation.

FUNDAMENTALS

SCREEN DISPLAY

◎ The screen data presentation system is as follows.

- S-1800 offers a variety of display modes in split screen by combination of Mode dials and Menu.

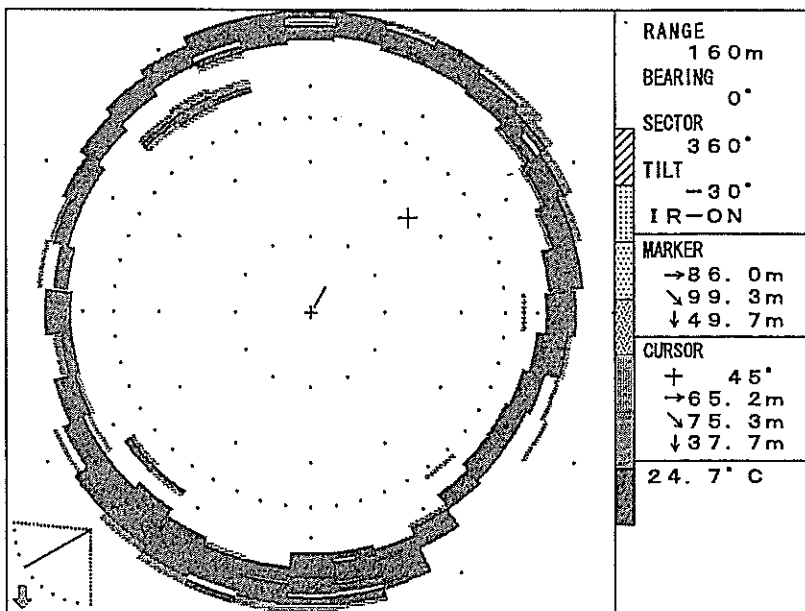

SPLIT SCREEN LEFT

- Sonar Mode
- Sonar Off-center Mode
- Bottom-Scan Mode
- Sounder Mode

Use Mode Dial to select displayed Mode.

SPLIT SCREEN RIGHT

- MENU 1 & Self check function
- MENU 2 & Self check function
- INFORMATION - Data display
- SUB-DISPLAY - various displays in split screen

Use Mode Dial to select MENU 1 or 2 .
Information - Data display and Sub-display can be applied in MENU 2.

- Range Dial provides 8 kinds of optimized user-defined ranges set in MENU 1.
- Fundamental appropriate menu settings can be applied in MENU 2
- Displays of HISTORICAL, +PRESS, +A-SCOPE, WAKE and EXT.F.F.(external fish finder) as well as INFORMATION - Data display can be applied and set in MENU 2.

SONAR MODE DISPLAY

☉ To select Mode Dial 1 or 2 to display the following sample.
Off-center display is activated when Mode 2 is selected.

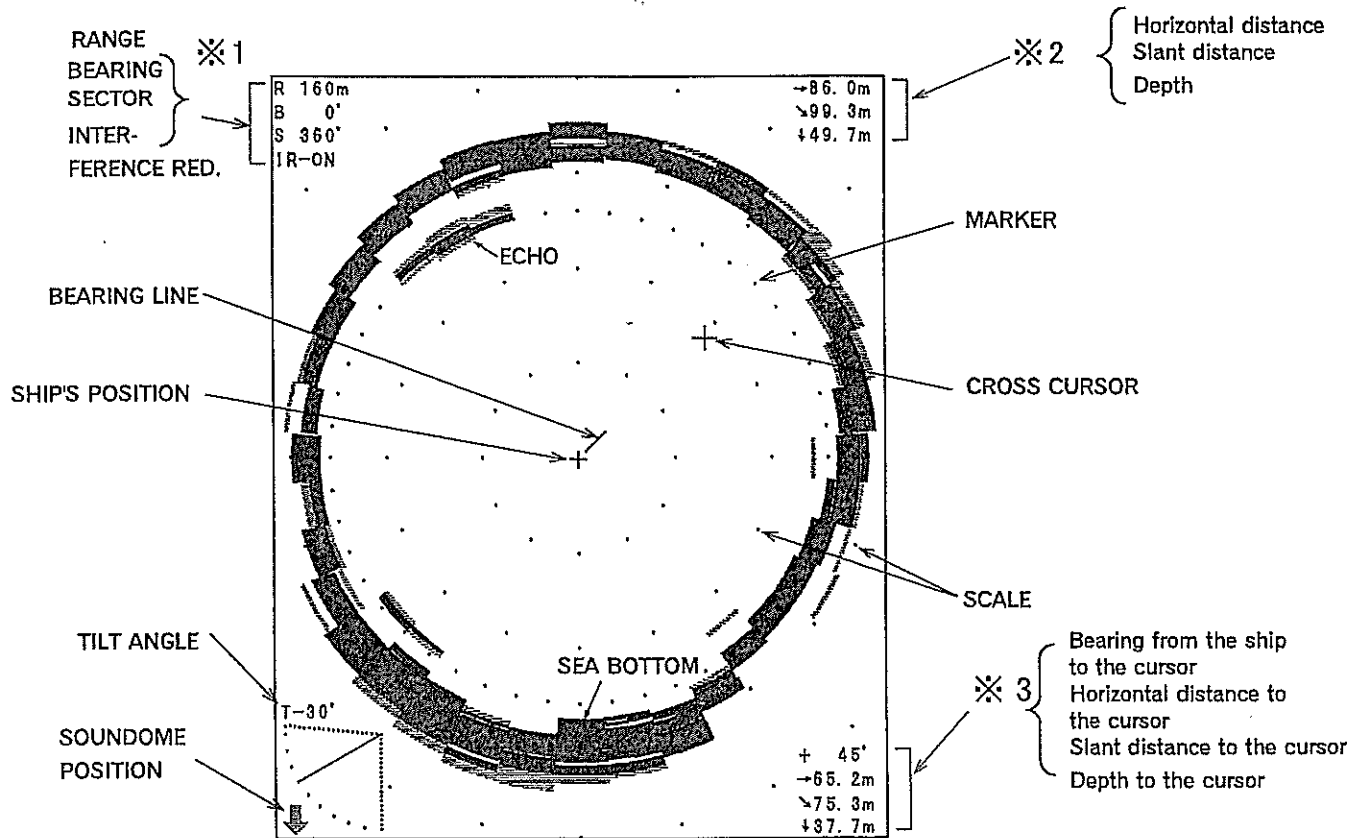

In SONAR MODE + INFORMATION displays on the split screen the above mentioned *1 to *3 and tilt angle are not displayed.

INFORMATION - Data display

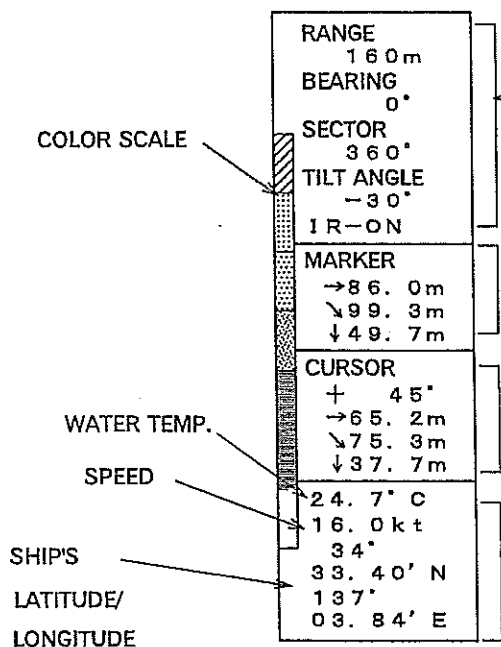

- The info will be displayed as the below-mentioned, selecting the item other than SUB-DISPLAY, INFORMATION .
- *1 on Sonar mode screen, top left. indicates the info left except Tilt angle. Tilt angle is displayed down left. "IR" will not be displayed when INTERFERENCE RED. function "OFF" is selected.
- *2 on Sonar mode screen, top right.
- *3 on Sonar mode screen, down right
- displayed on Sub-Display down.
- * To present this info will require S-1800 is connected to an external navigator.

SONAR MODE OPERATIONS

(1) SEARCH LIGHT MODE

- ◎ The Soundome transducer sends out a beam of ultra sonic sound which sweeps in the specified sector and bearing.
- The echoes of reflected sound waves are picked up by the transducer and displayed like a radar in their respective range and direction on the Display Unit screen.
- By adjusting the Tilt and Bearing the Sonar beam may be trained from the surface to the bottom.

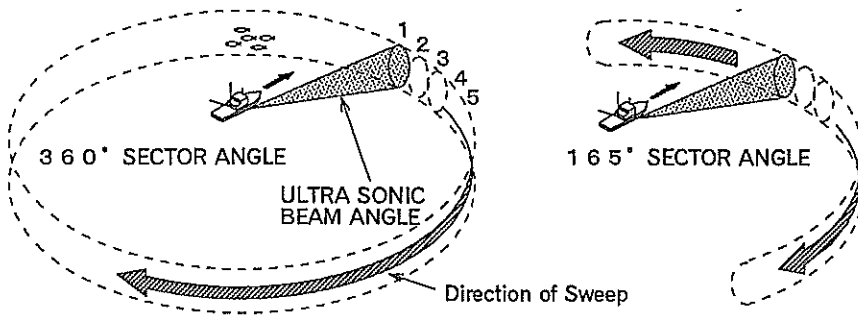

- Changing the sector angle makes it possible to detect in various ranges.

CF page 86

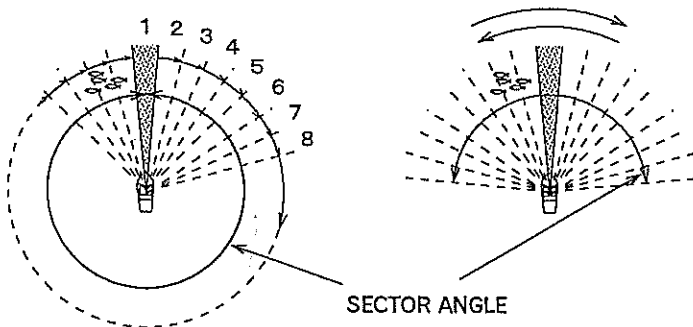

- The echoes received from the sound beam (1 → 2 → 3 ~) are displayed on the screen in that order.

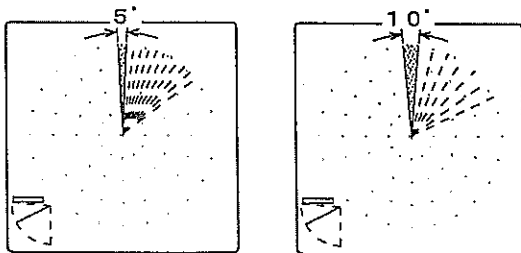

180/80 kHz

- The sector is covered by the Sonar beam in the selected step angle.
 - The reflected echo is displayed in order in the angle specified.
 - The step angle can be selected in Menu 2 - STEP (SONAR) .
- CF** page 71.
- A narrow step gives a more detailed image on the screen, however mores weep time is requested than a wide step.

(2) 45° SECTOR SCAN MODE – 150kHz

- ◎ The Soundome transducer sends out a beam of ultra sonic sound which sweeps in the steps of 45° sector and bearing (22.5° in the both sides, right and left from the center of the soundome).
- The echoes of reflected soundwaves are picked up by the transducer and displayed in their respective range and direction on the Display Unit screen.
- By adjusting the Tilt and Bearing the Sonar beam may be trained from the surface to the bottom.

- The sweep angle (Sector) can be selected.
(45°, 135°, 225°, 315°, 360°)

CF page 86

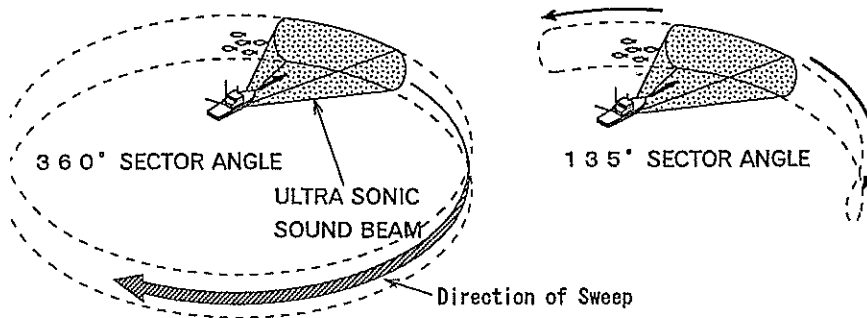

Sector angle
Select the angle from 45°, 135°, 225° and 360°.

ULTRA SONIC BEAM (view from above)

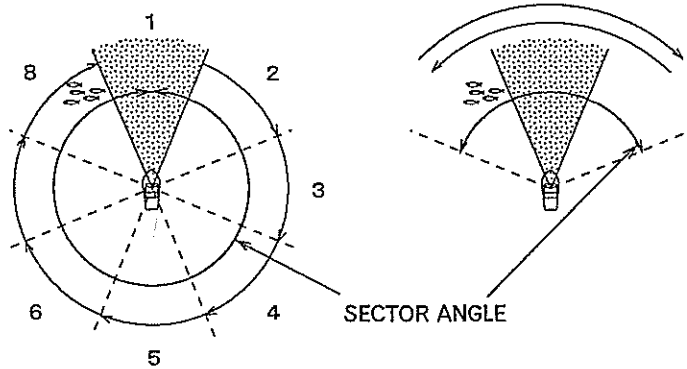

- The echoes received from the sound beam (1 → 2 → 3 ~) are displayed on the screen in that order.

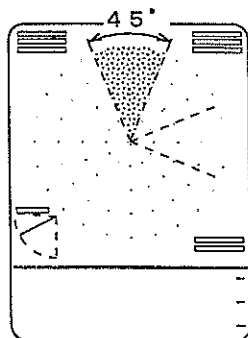

- The sector is covered by the Sonar beam in steps of the 45°..
- The echoes of the reflected sound waves are displayed in order at every 45° step .
- The 45° step gives a broader ranged and speedy display than that by Search light mode on the screen.

FUNDAMENTALS

© The Tilt angle can be changed from 5° above horizontal to -90° vertical in a 1° step.

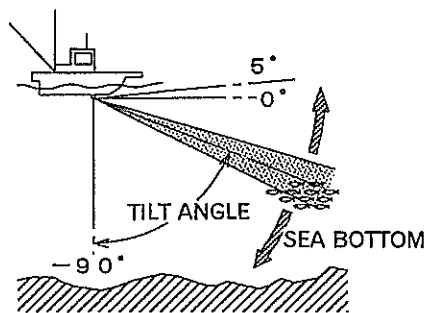

- With this range all directions from extremely shallow waters to deep areas may be searched.
- When adjusting the tilt angle please consider the conditions such as boat speed and water depth.

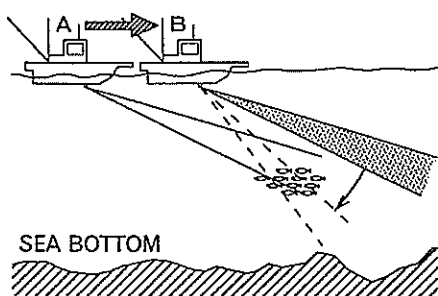

- If the vessel should proceed with the Sonar beam at the same angle at point A, the fish school echo will be displayed but when the vessel reaches point B. The beam will pass above the fish school and no echo will be displayed.
- In order to display the fish school at point B, adjust the Tilt angle so that the Sonar beam strikes the target.

The Tilt angle of the sonar soundbeam can only be changed when the soundbeam is in Sonar Mode, Bottom Scan Mode and Sounder Mode. **CF** page 90

BOTTOM SCAN MODE DISPLAY

☉ To select Mode dial 3 to display the following sample.

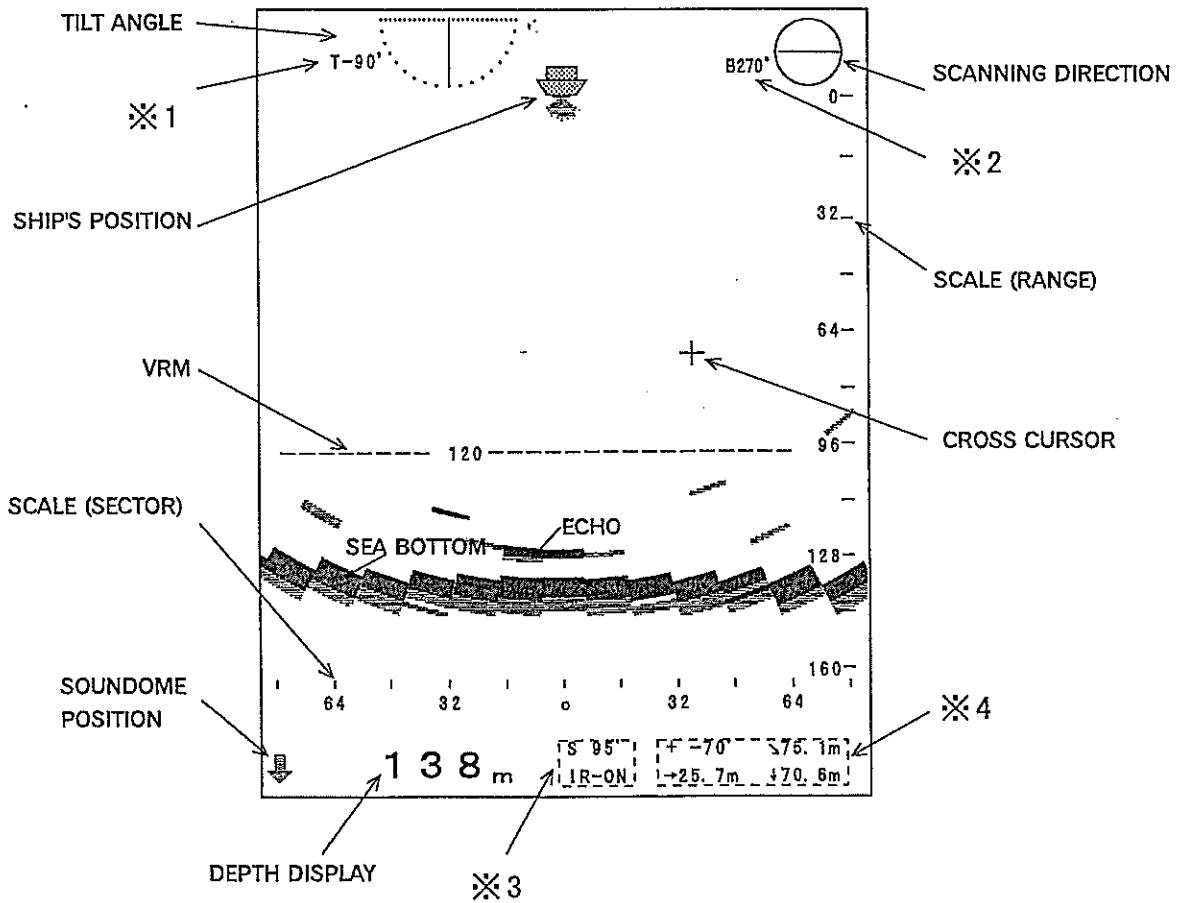

In BOTTOM SCAN MODE + INFORMATION displays on the split screen the above mentioned *1 to *4 are not displayed.

INFORMATION - Data display

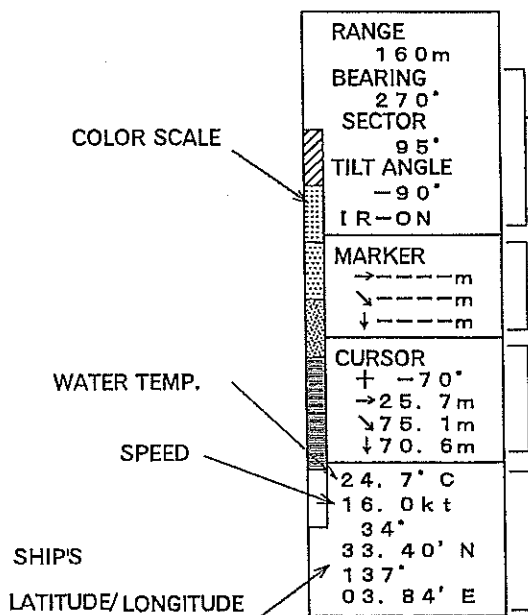

The info will be displayed as the below-mentioned, selecting the item other than SUB-DISPLAY, INFORMATION.

*1, *2 and *3 on Sonar mode screen indicate the info left.

"IR" will not be displayed when INTERFERENCE RED. function "OFF" is selected.

VRM on Bottom Scan mode screen.

*4 on Sonar mode screen.

displayed on Sub-Display down.

* To present this will require S-1800 is connected an external navigator.

FUNDAMENTALS

BOTTOM SCAN MODE OPERATIONS

- ◎ The Sonar beam sweeps from side to side underneath the vessel.
The screen will clearly display echoes from the middle depth and the sea-bottom contour.

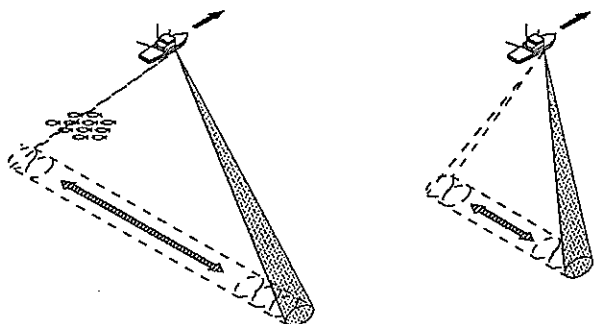

- The ultra sonic sound beams out as the beam sweeps from side to side.

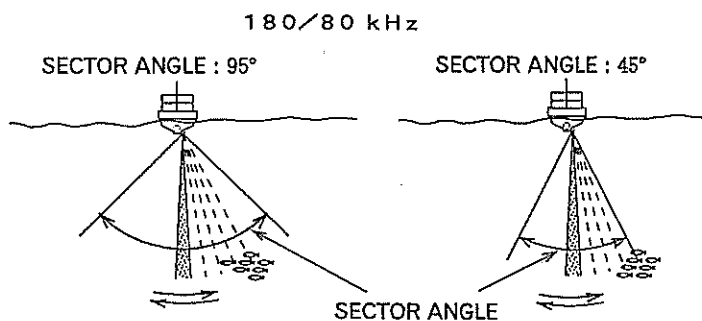

- Choose the size of the area to be scanned by changing Sector angle.
CF page 86
- The specified Sector angle is centered on the bearing line.
CF page 90

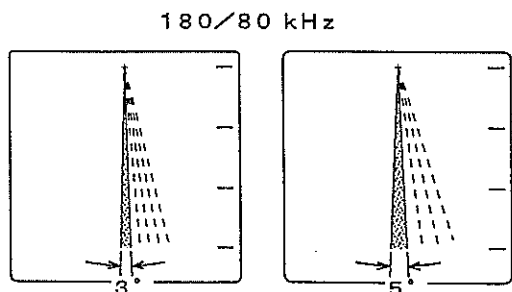

- The sector is covered by the Sonar beam in steps of the specified angle.
- The reflected echo is displayed in order in the angle specified.
- The step angle may be selected in the Menu 2 - STEP (BOTTOM SCAN).

CF page 72

SOUNDER MODE DISPLAY

☉ To select Mode dial 4 to display the following sample.

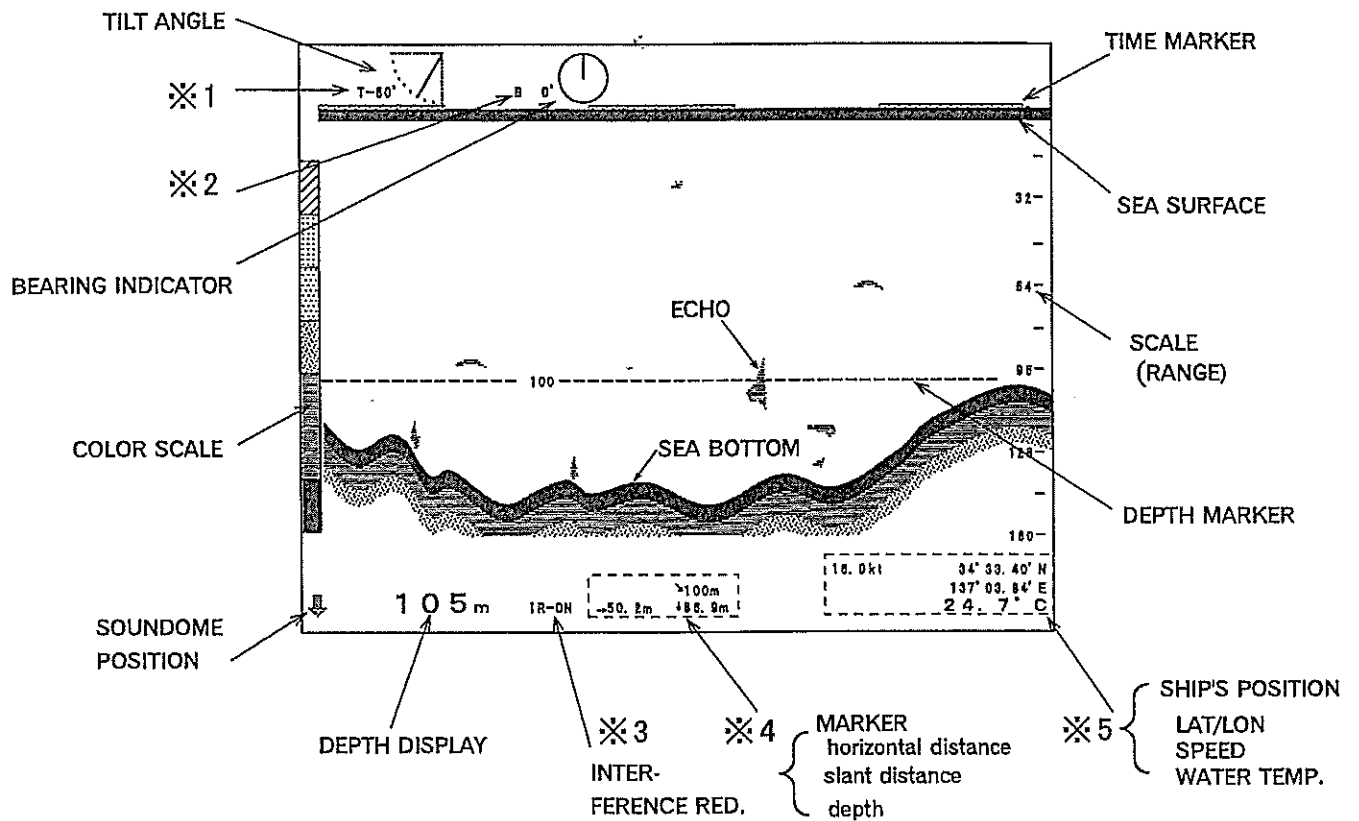

In SOUNDER MODE + INFORMATION displays on the split screen the above mentioned ※ 1 to ※ 5 are not displayed.

INFORMATION - Data display

The info will be displayed as the below-mentioned, selecting the item other than SUB-DISPLAY, INFORMATION.

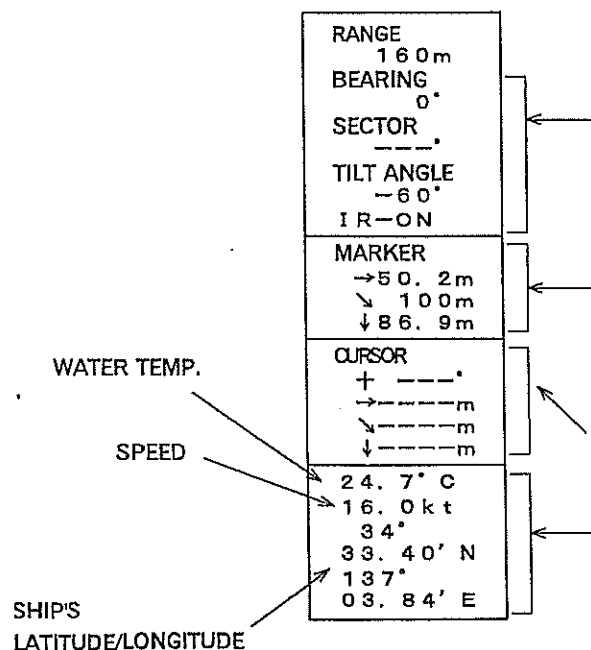

※1, ※2 and ※3 on Sounder mode screen indicate the info left. "IR" will not be displayed when INTER-FERERENCE RED. function "OFF" is selected.

VRM on Sounder mode screen and ※4 on Sounder mode screen indicates its Data.

not displayed on Sounder mode screen

displayed on Sounder mode screen or on ※5 on Sub-Display screen

* To present this will require S-1800 is connected an external navigator.

FUNDAMENTALS

SOUNDER MODE

◎ The Sonar beam sweeps underneath the vessel and S-1800 can be used as echo sounder mode by selecting Mode dial 4.

The screen will clearly display echo sounder images from the middle depth and the sea-bottom contour.

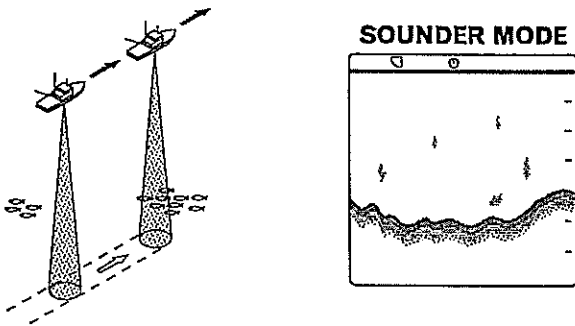

detects underneath the vessel.

- When operating in the SOUNDER MODE, the soundome tilts 90° and stops rotating and the sounder image is displayed on the screen.
- The beam width is relative to the frequency.

detects fore by changing Tilt angel.

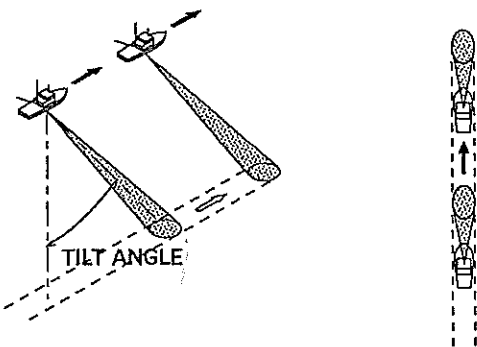

- The sounder image other than that of underneath the vessel can be displayed by changing Tilt angle and detetive direction.

CF page 89/90/91

detects fore by changing Tilt angel and Bearing .

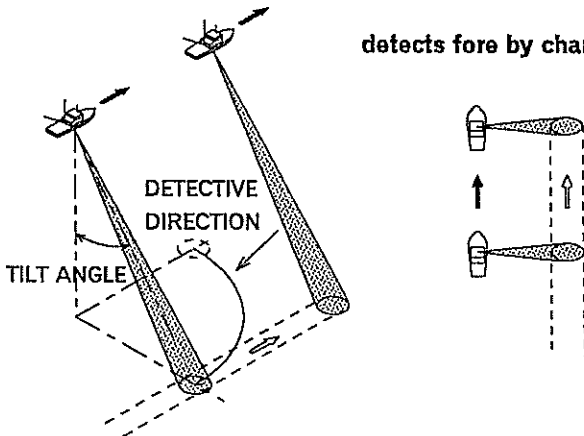

INITIAL SETTINGS

FACTORY SETTINGS (180/80kHz)

© The S-1800 is shipped from the factory with the functions under the settings listed below. Before using it, please enter the functions to the desired setup.

FUNCTIONS	FACTORY SETTINGS (in the item □)	SETTING MENU
FUNCTION SET GAIN UP TVG CURVE DYNAMIC RANGE PULSE WIDTH TX POWER	OFF • +10dB • +20dB • +30dB • +40dB OFF • 10LOG • 20LOG • 30LOG • 40LOG 1 dB • 2 dB • 3 dB X1 • X1.5 • X2 A • B • C • D	Change at Menu 2 CF (pages 59)
REDUCTION INTERFERENCE RED.	OFF • ON	
DISP ITEM SEL. SUB-DISPLAY STEP (SONAR) STEP (BOTTOM-SCAN) OFF-CENTER POS. SCALE DOTS COMPASS DISP. WAKE DISP. WAKE SUB RANGE WAKE MEM. INTERVAL PRESS RATE	INFORMATION • HISTORICAL • +PRESS • + A-SCOPE • WAKE • EXT. F. F. 5° • 10° 3° • 5° FORE • BACK • RIGHT • LEFT OFF • ON OFF • ON OFF • ON 50m (10~500m) 5 SEC. • 10 SEC. • 30 SEC. • 60 SEC. 1/2 • 1/4 • 1/8 • 1/16	
OTHERS AUDIO LEVEL TARGET LOCK TRIGGER SIGNAL DEPTH UNIT TEMP. UNIT TEMP. ADJUST SPEED UNIT HOIST AUTO UP TRAIN CORRECT PANEL BRIGHTNESS COLOR	0 (0~39) MODE0 • MODE1 • MODE2 • MODE3 INTERNAL • EXTERNAL m • br • fm • ft °C • °F +0.0°C (-9.9°~+9.9°) kt • km/h OFF • 10kt 0° (0°~355°) BRIGHT • DARK A-1 • A-2 • B-1 • B-2 • C-1 • C-2	
REMOTE CONTROL SET	SELECT OPTIMIZED FUNCTIONS	
RANGE SET MENU SONAR/OFF-CENTER RANGE BOTTOM-SCAN/ F.F. RANGE	SELECTABLE 8 RANGES	Change at Menu 1 CF (pages 57)
OPERATION MODE 1, 2, 3 USER'S SETTINGS	NO SETTINGS NO SETTINGS	





FACTORY SETTINGS (150kHz)

◎ The S-1800 is shipped from the factory with the functions under the settings listed below. Before using it, please enter the functions to the desired setup.

FUNCTIONS	FACTORY SETTINGS (in the item □)	SETTING MENU
FUNCTION SET GAIN UP TVG CURVE DYNAMIC RANGE PULSE WIDTH TX POWER	OFF · <input type="checkbox"/> 10dB · +20dB · +30dB · +40dB OFF · 10LOG · <input type="checkbox"/> 20LOG · 30LOG · 40LOG 1 dB · 2 dB · <input type="checkbox"/> 3 dB NARROW · <input type="checkbox"/> NORMAL · WIDE · 0.3 ms A · B · C · <input type="checkbox"/> D	Change at Menu 2 <input type="checkbox"/> CF (pages 59)
REDUCTION NOISE REDUCTION INTERFERENCE RED.	<input type="checkbox"/> OFF · ON <input type="checkbox"/> OFF · ON	
DISP ITEM SEL. SUB-DISPLAY STEP (SONAR) STEP (BOTTOM-SCAN) OFF-CENTER POS. SCALE DOTS COMPASS DISP. WAKE DISP. WAKE SUB RANGE WAKE MEM. INTERVAL PRESS RATE	<input type="checkbox"/> INFORMATION · HISTORICAL · +PRESS · + A-SCOPE · WAKE · EXT. F. F. 6° · 12° · 18° · <input type="checkbox"/> 45° 6° · <input type="checkbox"/> 12° <input type="checkbox"/> FORE · BACK · RIGHT · LEFT <input type="checkbox"/> OFF · <input type="checkbox"/> ON <input type="checkbox"/> OFF · ON <input type="checkbox"/> OFF · ON <input type="checkbox"/> 50m (10~500m) <input type="checkbox"/> 5 SEC. · 10 SEC. · 30 SEC. · 60 SEC. 1/2 · <input type="checkbox"/> 1/4 · 1/8 · 1/16	
OTHERS AUDIO LEVEL TARGET LOCK TRIGGER SIGNAL DEPTH UNIT TEMP. UNIT TEMP. ADJUST SPEED UNIT HOIST AUTO UP STABILIZER TRAIN CORRECT PANEL BRIGHTNESS COLOR	<input type="checkbox"/> 0 (0~39) <input type="checkbox"/> MODE0 · MODE1 · MODE2 · MODE3 <input type="checkbox"/> INTERNAL · EXTERNAL <input type="checkbox"/> m · br · fm · ft <input type="checkbox"/> C · °F <input type="checkbox"/> +0.0°C (-9.9°~+9.9°) <input type="checkbox"/> kt · km/h <input type="checkbox"/> OFF · 10kt <input type="checkbox"/> OFF · ON <input type="checkbox"/> 0° (0°~355°) <input type="checkbox"/> BRIGHT · DARK <input type="checkbox"/> A-1 · A-2 · B-1 · B-2 · C-1 · C-2	
REMOTE CONTROL SET	SELECT OPTIMIZED FUNCTIONS	
RANGE SET MENU SONAR/OFF-CENTER RANGE BOTTOM-SCAN/ F.F. RANGE	SELECTABLE 8 RANGES	Change at Menu 1 <input type="checkbox"/> CF (pages 57)
OPERATION MODE 1, 2, 3 USER'S SETTINGS	NO SETTINGS NO SETTINGS	

INITIAL SETTING

RETURN TO FACTORY SETTINGS

- ⊙ First press the Power OFF key, then press **ON** key while pressing both   at the same time.
Keep pressing the   keys until the beep sound stops.
- Activating this operation will erase all settings excluding "Train Correct" at Menu 2, and restore the basic settings from the factory.

USER SETTINGS

- ⊙ Separate to the Factory Setting function, Settings may be entered by the user and memorized. This function is called "User Settings". By entering "User Settings" the S-1800 to suit individual needs can be done. This not only simplifies operation of the S-1800, but adds considerably to its reliability.
- All user implemented data in the S-1800 can be erased by making a reset of the unit and thus return to "User settings". Please ensure the "User settings" are memorized on the first operation.

1. MEMORIZE USER SETTINGS

- First ensure the functions are at the desired settings.
- After disconnecting the power supply once by pressing the power supply **OFF** key, then turn the power supply back on, while pressing both **1** and **ON** keys at the same time. Keep pressing the **1** and **ON** keys until the beep sound stops.
- After completing this operation all functions and their units will be memorized as set by the user.

2. RETURN TO USER SETTINGS

- In case, for some reason, the S-1800 become inoperable, the unit can be reset by disconnecting the power supply and then turn the power supply back on, while pressing the **3** and **ON** keys at the same time. Keep pressing the **3** key until the beep sound stops.
- This operation can return to User Settings.

3. CHANGING USER SETTINGS

- To change the functions in User Settings first activate "Return to Factory Settings" and then memorize "User Settings" again as described in the previous item 1





NOTE !

Releasing the keys before the beep sounds stops may not complete the job.
Performing "Return to Factory Settings" will return all settings to Factory Settings and erase all User Settings.

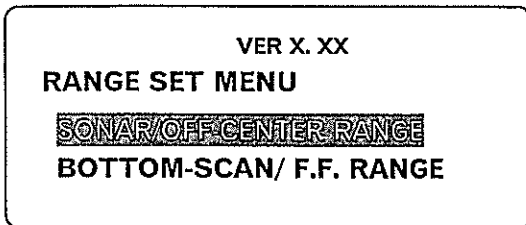



MENU 1 (RANGE SET MENU)

- One of eight ranges can be quickly selected using this function and each of these ranges can be set by the user to meet his own requirements using RANGE dial.
- The following will be displayed by selecting MENU 1 of MODE dial.





- Use the cursor selection key  or  to highlight the item you wish to change. By pressing the cursor selection key  or  the following is displayed.
- Refer to the next page for 8 available ranges.

Range Number	Range Value (m)
1	4 0 m
2	8 0 m
3	1 2 0 m
4	1 6 0 m
5	2 0 0 m
6	2 4 0 m
7	2 8 0 m
8	3 2 0 m



- Use the cursor selection key  or  to highlight the number you wish to change.
- Each press of  or  key change the range related to the basic ranges listed in the next page.

cursor selection key

-  : makes the range value smaller.
-  : makes the range value larger.

- indicates RANGE DIAL numbers .

The initial set values of SONAR/OFF-CENTER RANGE differ from those of BOTTOM-SCAN/ F.F. RANGE. Depth units can be selected from MENU 2 → OTHERS → DEPTH UNIT. Each range value of both SONAR/OFF-CENTER RANGE and BOTTOM-SCAN/ F.F. RANGE should be entered.

The range values can be selected from the list shown in the next page by pressing the   keys, however the values of OFF-CENTER can be displayed automatically when OFF-CENTER MODE is activated.

<To be continued>

MENU

H180/H80 (180kHz/80kHz)
BASIC RANGE (BASIC DEPTH)

 initial values

RANGE	MT			BR·FM			FT		
	NORMAL	OFF-CENTER	BOTTOM-SCAN	NORMAL	OFF-CENTER	BOTTOM-SCAN	NORMAL	OFF-CENTER	BOTTOM-SCAN
1	-	-	10	-	-	6	-	-	40
2	-	-	15	-	-	9	-	-	60
3	20	30	20	12	18	12	80	120	80
4	30	60	40	20	30	20	100	150	100
5	60	90	135	30	45	30	120	180	120
6	80	120	80	40	60	40	160	240	160
7	100	150	100	50	75	50	200	300	200
8	120	180	120	60	90	60	240	360	240
9	140	210	140	80	120	80	280	420	280
10	160	240	160	100	150	100	320	480	320
11	180	270	180	120	180	120	360	540	360
12	200	300	200	160	240	160	400	600	400
13	240	360	240	200	300	200	500	750	500
14	280	420	280	240	360	240	600	900	600
15	320	480	320	280	420	280	700	1050	700
16	360	540	360	320	480	320	800	1200	800
17	400	600	400	360	540	360	900	1350	900
18	500	750	500	400	600	400	1000	1500	1000
19	600	900	600	500	750	500	1200	1800	1200
20	700	1050	700	600	900	600	1600	2400	1600
21	800	1200	800	700	1050	700	2000	3000	2000
22	900	1350	900	800	1200	800	2400	3600	2400
23	1000	1500	1000	900	1350	900	3200	4800	3200
24	1200	1800	1200	1000	1500	1000	4000	6000	4000
25	1600	2400	1600	1200	1800	1200	5000	7500	5000
26	2000	3000	2000	1600	2400	1600	6000	9000	6000

H150 (150kHz)
BASIC RANGE (BASIC DEPTH)

RANGE	MT			BR·FM			FT		
	NORMAL	OFF-CENTER	BOTTOM-SCAN	NORMAL	OFF-CENTER	BOTTOM-SCAN	NORMAL	OFF-CENTER	BOTTOM-SCAN
1	40	60	40	20	30	20	120	180	120
2	60	90	60	40	60	40	160	240	160
3	80	120	80	60	90	60	200	300	200
4	100	150	100	80	120	80	240	360	240
5	120	180	120	100	150	100	280	420	280
6	160	240	160	120	180	120	320	480	320
7	200	300	200	160	240	160	400	600	400
8	240	360	240	200	300	200	600	900	600
9	280	420	280	240	360	240	800	1200	800
10	320	480	320	280	420	280	1000	1500	1000
11	400	600	400	320	480	320	1200	1800	1200
12	600	900	600	400	600	400	1600	2400	1600
13	800	1200	800	600	900	600	2400	3600	2400
14	1000	1500	1000	800	1200	800	3200	4800	3200
15	1200	1800	1200	1000	1500	1000	4000	6000	4000
16	1600	2400	1600	1200	1800	1200	5000	7500	5000
17	2000	3000	2000	1600	2400	1600	6000	9000	6000

MENU 2 (FUNCTION SET MENU)

- ◎ Basic functions may be briefly described in the following.
 - Before first using the S-1800, customizing the functions to suit individual needs.
 - Turn the mode selection dial to "MENU 2" to display the menu below.

MAIN MENU

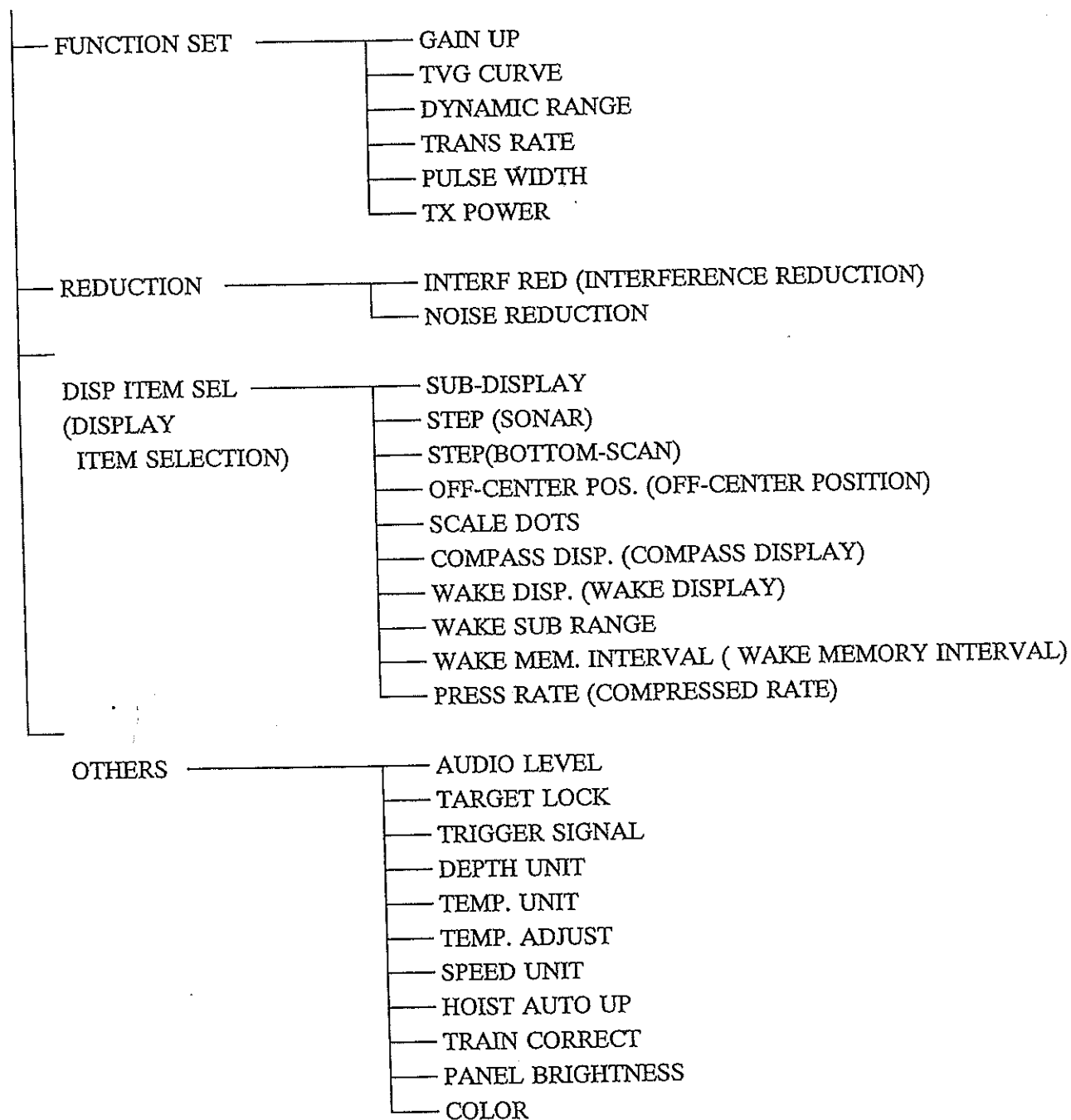





REMOTE CONTROL SET — OPTION
 Note is attached to the remote control kit.

* For more detailed explanation, refer to the following pages.

FUNCTION SETTINGS

MAIN MENU

- ◎ Turn the mode selection dial to "MENU 2" to display the menu below.
- Use the cursor selection key  or  to highlight the item you wish to change.
- By pressing the cursor selection key  or  the following is displayed.

VER 0.00E

MAIN MENU

FUNCTION SET

REDUCTION

DISP ITEM SEL.

OTHERS

REMOTE CONTROL SET

SELF CHECK

DATA-TX OK

DATA-RX OK

DATA OK





HOIST OK

TILT OK

TRAIN OK

ROM-VER OK

OTHERS OK

- Version No. of EPROM
- Use the cursor selection key  or  to highlight the item you wish to change.
- The setup display is accessed by pressing the cursor selection key  or .

- SELF CHECK function
- The test result is displayed
- Test result : OK
- Tesu result no good : NG in red

• not displayed in 150kHz frequency.

SETTING FUNCTIONS

FUNCTION SET

RETURN MAIN MENU

GAIN UP OFF

TVG CURVE 30 LOG

DYNAMIC RANGE 3 d B

PULSE WIDTH X1

TX POWER D

GAIN





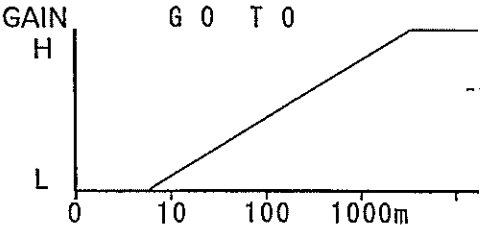

H

G O T O



L





0 10 100 1000m

- Use the cursor selection key  or  to return to MAIN MENU.
- Use the cursor selection key  or  to highlight the item you wish to change.
- Press  or  key to select the desired setting.
- Graph for Gain Characteristics displays the changed gains such as TVG curve, Gain Up, Gain dial and Far Gain dial etc.

※ Different values and graph will be displayed in 150kHz frequency.

1. GAIN UP

⊙ This function makes it possible to display a clearer picture of the full range and control the sensitivity at various depths.

- Highlight the "GAIN UP" function by means of   keys and select the desired values by   keys.

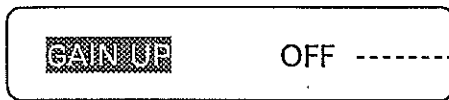

• Each press of  or  key changes the settings "OFF → + 10dB → + 20dB → + 30dB → + 40dB".

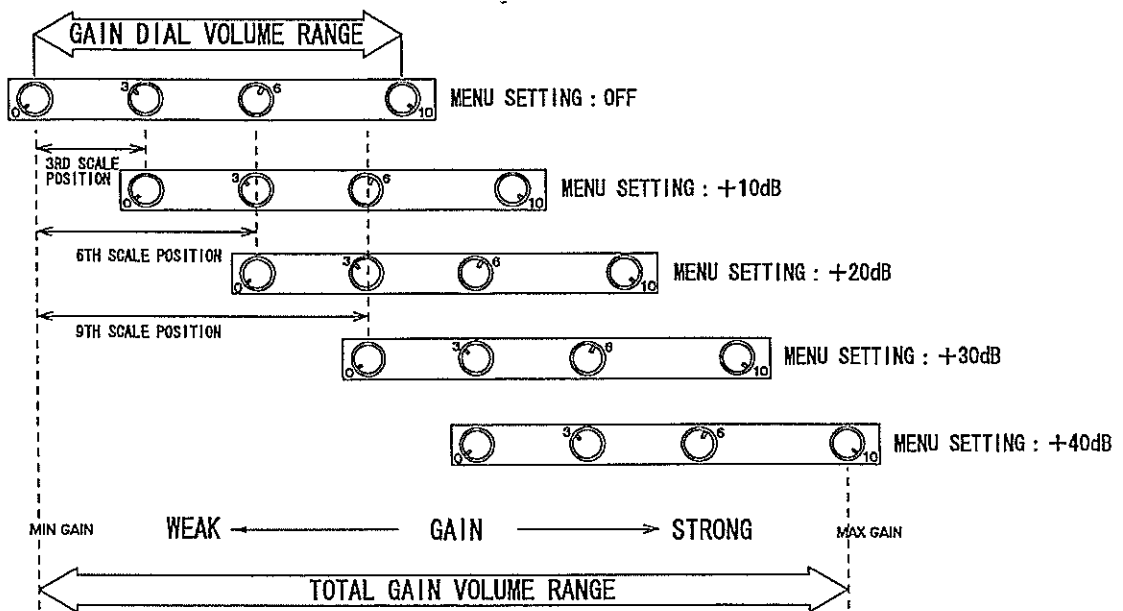

- When the menu gain adjust setting is changed from OFF to + 10dB, the gain dial volume increases 3 points on the scale.
- When the menu gain adjust setting is OFF and the front panel dial is on 3, it has the same result as when the menu gain adjust setting is on + 10dB and the gain dial is on 0.

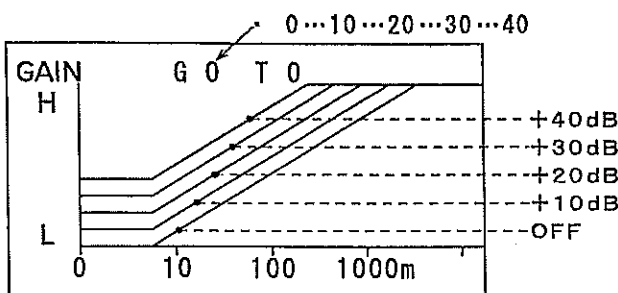





- Selected GAIN UP, Gain Characteristics Diagram shifted accordingly shows left under the following conditions.
 Gain dial : 0
 Far Gain dial : 0
 TVG Curve : 30LOG



FUNCTION SETTINGS

2. TVG CURVE

◎ TVG offsets the effects of propagation loss of sound as it passes through the water. Propagation loss of sound is the sum of spreading and attenuation losses. The TVG curve is adjusted to counter the loss.

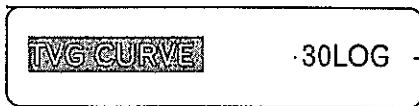
- Highlight the "TVG CURVE" function by means of   keys and select the desired values by   keys.



• Each press of  or  key changes the settings "OFF → 10LOG → 20LOG → 30LOG → 40LOG"

- OFF : STC function in 150kHz frequency and the TVG is inactive in 180/80kHz frequencies.
- 10LOG : Curve ① in the below drawing.
- 20LOG : Curve ② in the below drawing.
- 30LOG : Curve ③ in the below drawing.
- 40LOG : Curve ④ in the below drawing.

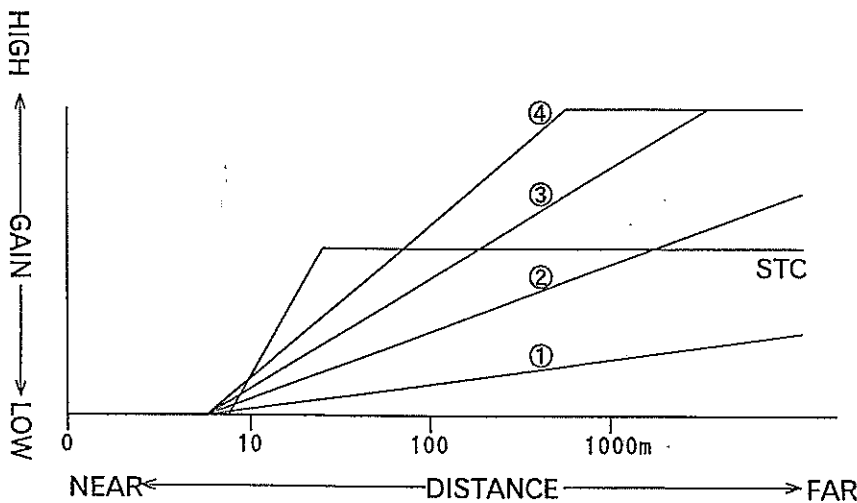





- In accordance with the distance the gain increases automatically even if the gain volume is unchanged as seen in the above drawing.

NOTE !



- ◎ Please note that the TVG settings and gain control by Gain dials have its affect mutually.

3. DYNAMIC RANGE

⊙ By shifting the dynamic range, the display to reflect the received echo more precisely or the display to discriminate their density is selected.

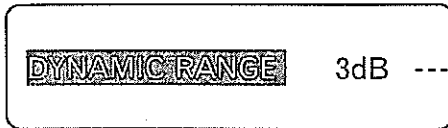
- Highlight the "DYNAMIC RANGE" function by means of   keys and select the desired values by   keys.



• Each press of  or  key changes the settings "OFF → + 10dB → + 20dB → + 30dB → + 40dB"



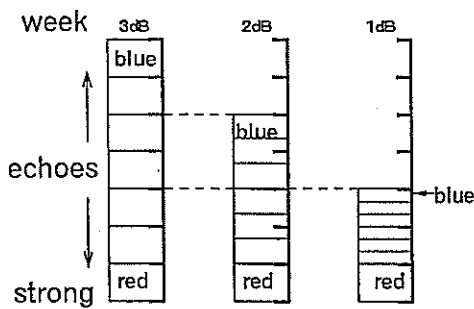

COLOR SCALE





The diagram shows the comparative signal threshold levels for the dynamic ranges.

4-1. PULSE WIDTH (180/80kHz)

⊙ The transmitted pulse width can be set.

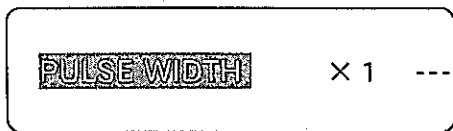
- Highlight the "PULSE WIDTH" function by means of   keys and select the desired values by   keys.



• Each press of  or  key changes the settings "x 1 ...x 1.5 ...x 2".

× 1 : automatically changes the transmit pulse width according to the range (normal) listed below.

× 1.5 : automatically the normal transmit pulse width x 1.5

× 2 : automatically the normal transmit pulse width x 2





A longer pulse width provides greater detective range.

RANGE (m)	PULSE WIDTH(msec)
0 ~ 59	0.25
60 ~ 79	0.40
80 ~ 99	0.75
100 ~ 119	0.90
120 ~ 159	1.00



RANGE (m)	PULTH WIDTH (msec)
160 ~ 199	1.25
200 ~ 239	2.00
240 ~ 399	2.50
400 ~	3.75

FUNCTION SETTINGS



4-2. PULSE WIDTH (150kHz)

- ◎ The transmitted pulse width can be set.
 - The transmitted pulse can be set to these three (narrow • normal • wide), where the optimum setting will be applied according to the range automatically. Or it can be set manually, if a specific pulse width (0.1 ~ 5.4 msec) is required.
 - Highlight the "PULSE WIDTH" function by means of   keys and select the desired pulse width of the transmitting pulse by   keys.

PULSE WIDTH NORMAL

• Each press of   keys changes the setting "NARROW - NORMAL - WIDE - 0.3 ms".

- NORMAL : Setting NORMAL changes automatically according to the range. Refer to the list below.
- NARROW : When the searching range is short and high more resolution is required,
- WIDE : the pulse width should be set NARROW. Normal pulse width x 0.5
: The longer range gives less resolution.
Normal pulse width x 1.5
- CONSTANT : The initial value of the pulse width is 0.3 msec. The pulse width is to be set every 0.1 msec unit from 0.1 to 5.4 msec.

- Use  key to select the larger values.
- Use  key to select the smaller values.

- List for the pulse width according to the range automatically

RANGE DEPTH (m)	PULSE WIDTH (msec)
0 ~ 59	0.2
60 ~ 79	0.4
80 ~ 99	0.6
100 ~ 119	0.8
120 ~ 159	1.0
160 ~ 199	1.2





RANGE DEPTH (m)	PULSE WIDTH (msec)
200 ~ 239	1.6
240 ~ 319	2.0
320 ~ 399	2.4
400 ~ 599	3.0
600 ~	3.6

NOTE !



- ◎ In actual practice, the short pulse width gives better resolution, and less noise in shallow water or surface scanning. The longer pulse width is selected, the lower resolution is given.

5. TX POWER

◎ The output power of the ultrasonic sound wave may be selected.

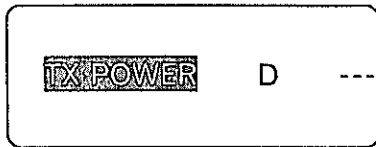
- In crowded fishing areas, this function may be used to reduce power and avoid interference to other Fishing boat's Sonars and Echo Sounders.
- Highlight the "TX POWER" function by means of   keys and select the desired level of the transmitting power by   keys.
- "D" indicates the maximum power and then gradually reduced by moving from "D" → "C" → "B" → "A" that is the minimum power.



• Each press of   keys changes the setting "D - C - B - A" .

FUNCTION SETTINGS

REDUCTION

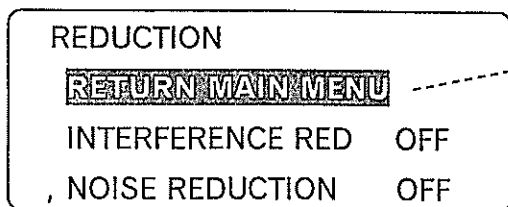

- Use the cursor selection key or to return to MAIN MENU.
- Use the cursor selection key or to highlight the item you wish to change.
- Press or key to select the desired setting.

• No display in 180/80kHz frequencies.

1. INTERFERENCE REDUCTION

◎ This function may be used to eliminate noise from other boats..

- Highlight the "INTERFERENCE RED" by means of keys and select the function "ON" or "OFF" by keys.

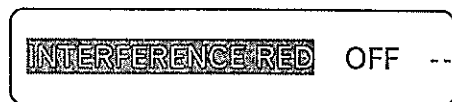

- Each press of or key changes the settings "ON → OFF".

- ON : Interference reduction is functioning.
- OFF : Interference reduction is not functioning.

2. NOISE REDUCTION (only in 150kHz)

◎ This function may be used to eliminate small noise.

- Highlight the "NOISE REDUCTION" by means of keys and select the function "ON" or "OFF" by keys.

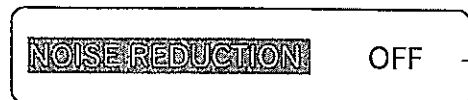

- Each press of or key changes the settings "ON → OFF".

- ON : Noise reduction is functioning.
- OFF : Noise reduction is not functioning.

NOTE !

- ◎ Please note that "NOISE REDUCTION" function is not available when 45° step is set under sonar mode.

DISPLAY ITEM SELECTION

DISP ITEM SEL.	
RETURN MAIN MENU	
SUB-DISPLAY	INFORMATION
STEP (SONAR)	1 0°
STEP (BOTTOM-SCAN)	5°
OFF-CENTER POS.	FORE
SCALE DOTS	ON
COMPASS DISP.	OFF
WAKE DISP.	OFF
WAKE SUB RANGE	50m
WAKE MEM. INTERVAL	5 SEC.
PRESS RATE	1 / 4

- Use the cursor selection key or to return to MAIN MENU.
- Use the cursor selection key or to highlight the item you wish to change.
- Press or key to select the desired setting.

※ Other values are shown in 150kHz frequency.

1. SUB-DISPLAY

◎ This function may be used to select the mode displayed on the right split screen.

- Highlight the "SUB-DISPLAY" by means of keys and select the desired setting by keys.

SUB-DISPLAY	INFORMATION
--------------------	-------------

- Each press of or key changes the settings, "INFORMATION → HISTORICAL → +PRESS → + A -SCOPE → WAKE → EXT.F.F."

① INFORMATION

◎ This can be activated by selecting the MODE dial 1 ~ 4.

RANGE 160m	←	displays the selected range.
BEARING 0°	←	displays the bearing angle set by the Bearing keys
SECTOR 360°	←	displays the sector angle set by the Sector keys.
TILT ANGLE -30°	←	displays the tilt angle set by the Tilt keys
IR-ON	←	displays only when the INTERFERENCE RED - ON is selected.
MARKER →86.0m ↘99.3m ↓49.7m	←	displays horizontal distance, slant distance and depth to the marker. not displayed in BOTTOM SCAN MODE.
CURSOR + 45° →65.2m ↘75.3m ↓37.7m	←	displays horizontal distance, slant distance and depth to the cursor. not displayed in SOUNDER MODE.
24.7°C	←	displays the water temperature.
16.0kt 34° 33.40' N 137° 03.84' E	←	displays the ship's speed and latitude/longitude. * To present this info will require S-1800 is connected to an external navigator.

FUNCTION SETTINGS

② HISTORICAL DISPLAY

- ⊙ This vertical writing display appears on the right split screen by HISTORICAL in SUB-DISPLAY under SONAR MODE and BOTTOM SCAN MODE. However, on selecting SOUNDER MODE the vertical sounding picture is full up on the screen.

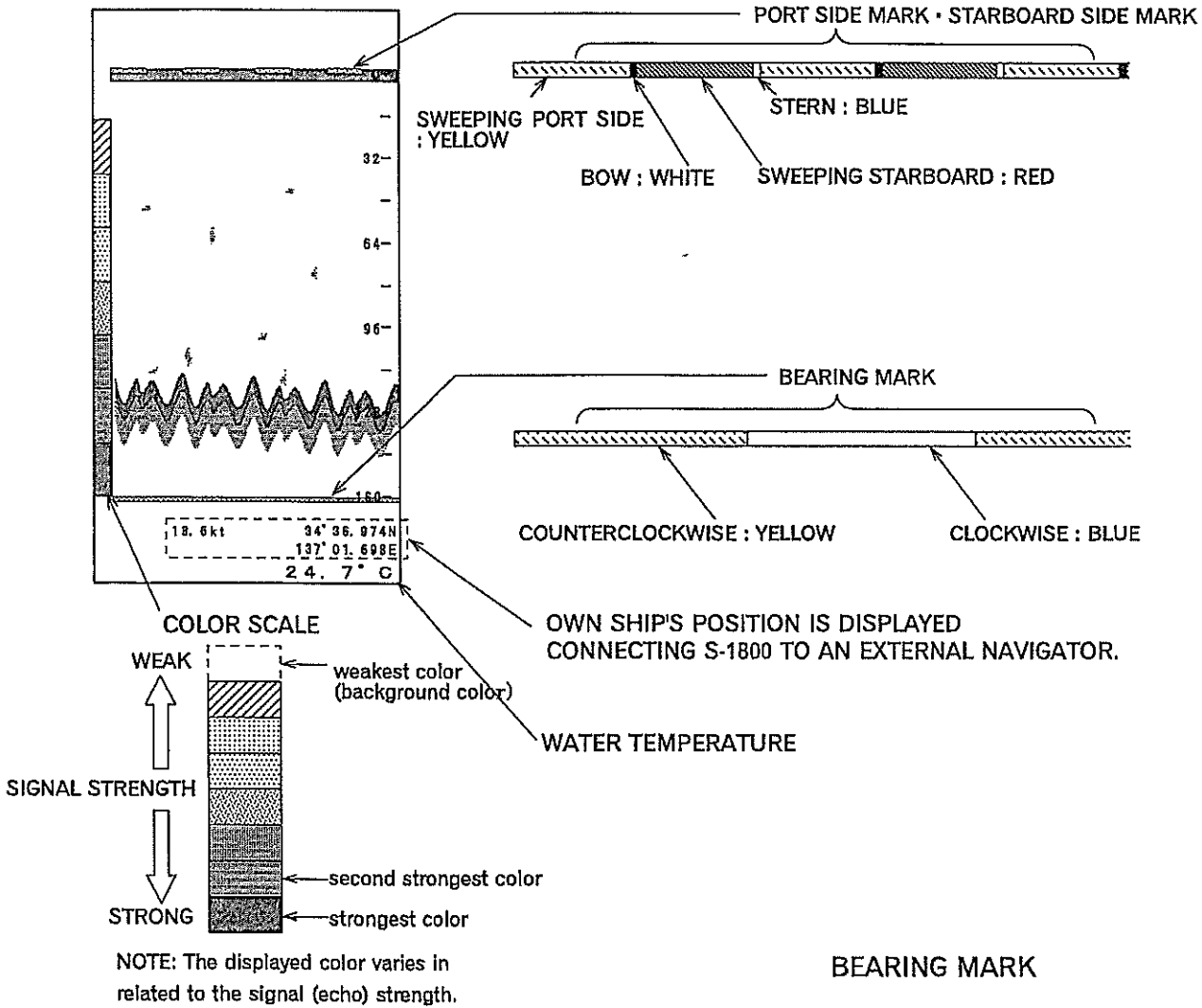

PORT SIDE MARK • STARBOARD SIDE MARK

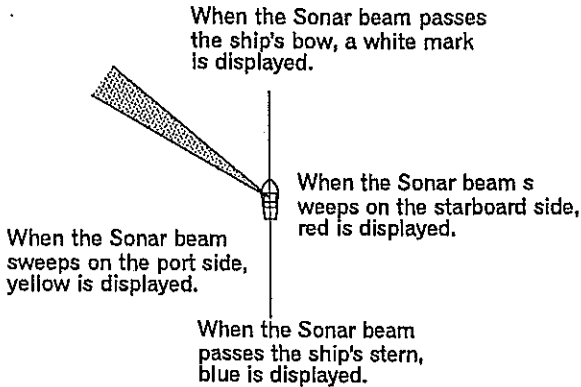

BEARING MARK

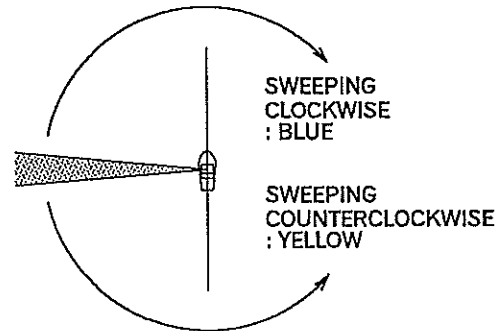

The mark color is displayed as shown in the color scale being related to the Sonar beam bearing direction.

The mark color is displayed as shown in the color scale being related to the Sonar beam direction (position).

③ + PRESS (COMPRESSED VERTICAL WRITING DISPLAY)

- ⊙ The vertical writing display and its compressed writing display appears on the right split screen by + PRESS in SUB-DISPLAY under SONAR MODE and BOTTOM SCAN MODE.

However, on selecting SOUNDER MODE the normal vertical sounding picture and its compressed picture appear in the right and left split screen..

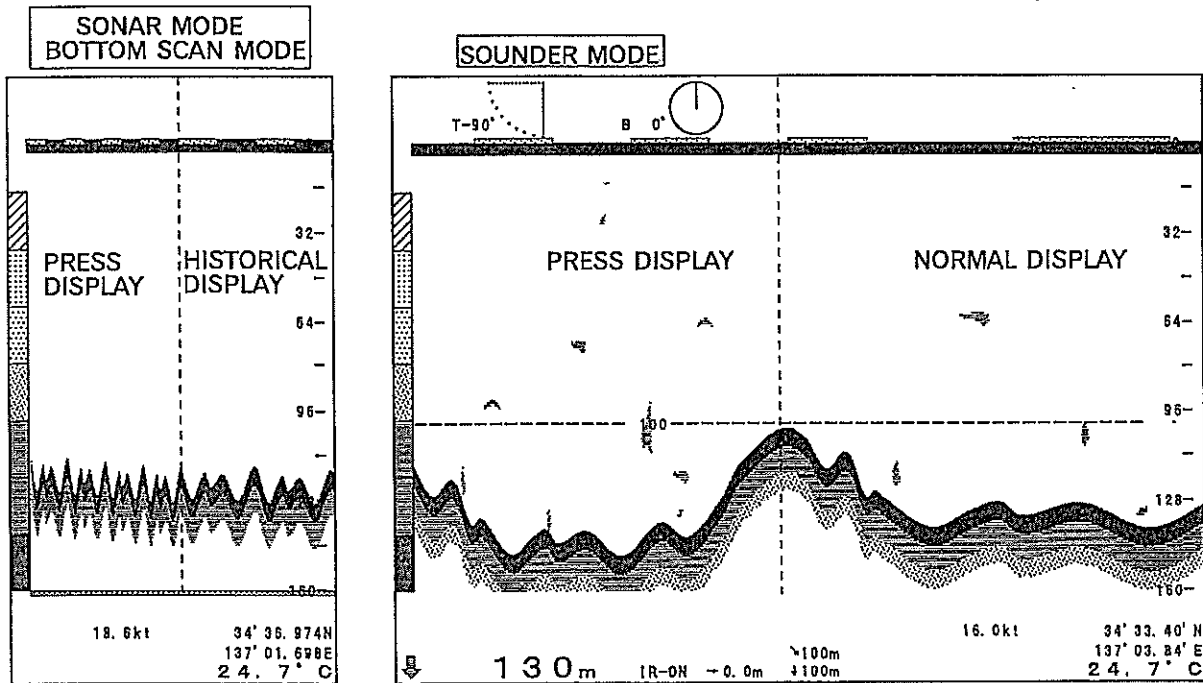

④ + A-SCOPE

- ⊙ A-SCOPE appears at the right side of the vertical writing display on the right split screen.
- The drawing below shows an example in SONAR MODE and BOTTOM SCAN MODE. A-Scope function is also available in SOUNDER MODE.

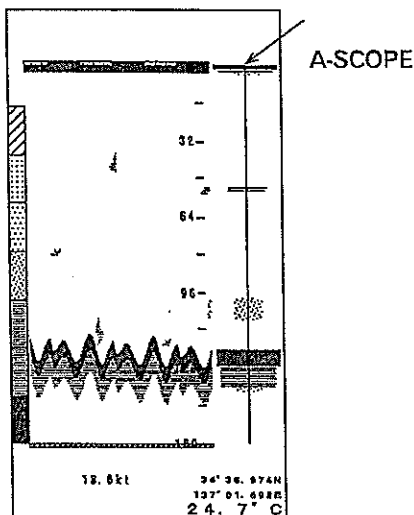

FUNCTION SETTINGS

⑤ WAKE

- ◎ By connecting S-1800 to an external navigator own ship's position can be shown on the screen.

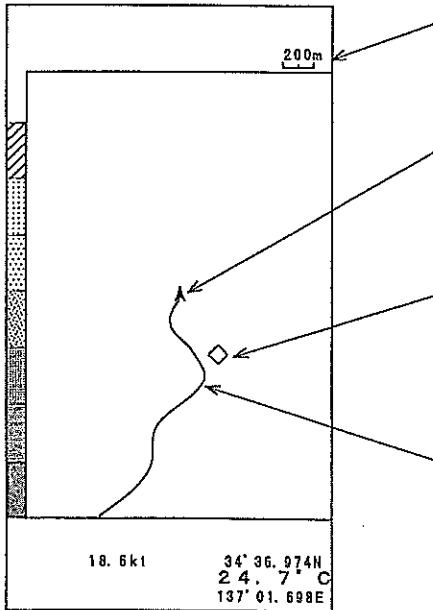

- **SCREEN WIDTH**
displays the screen width selected by "WAKE SUB RANGE".
- **OWN SHIP**
displays own ship's position in latitude/longitude and speed at the bottom of the split screen..
- **MARK**
displays marks placed by the cross cursor in SONAR MODE screen.
- **WAKE (TRACK)**
The wake (track) is initially saved into memory every 2 seconds. The previous wake saving periods can be selected via the procedure of "WAKE MEM. INTERVAL".

※ No color scale appears on Sounder Mode screen.



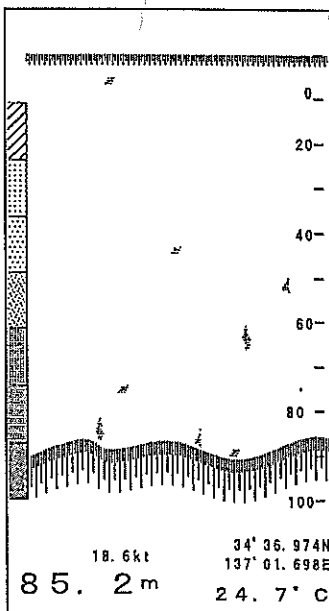

⑥ EXT.F.F. (EXTERNAL FISH FINDER)

- ◎ This function is only available for the case that S-1800 is connected to an echo sounder with TORATAN system.





2. STEP (SONAR)

◎ The step angle (scanning angle) in the Sonar mode may be selected.

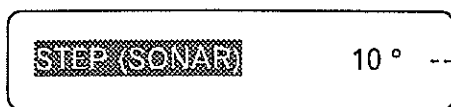
· Highlight the "STEP (SONAR)" function by means of   keys and select the desired step angle by   keys.



· Each press of  or  key changes the angles "5° → 10°" in 180/80kHz frequency and "45° → 6° → 12° → 18°" in 150kHz frequency.

※ 180/80kHz frequencies

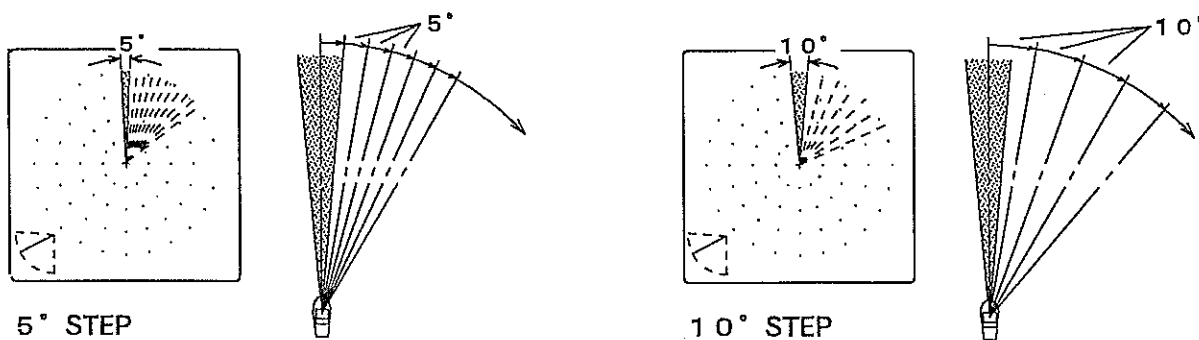

※ 150kHz frequency

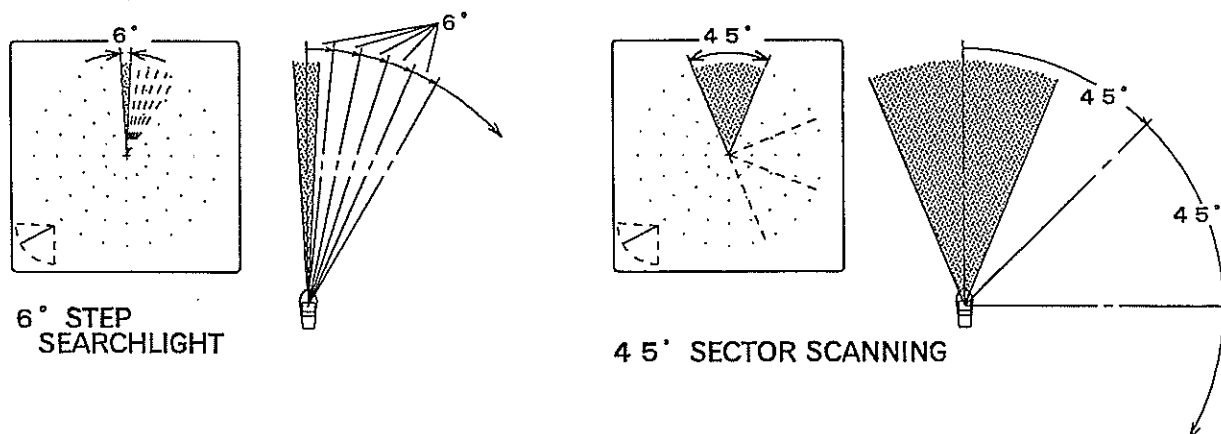





NOTE !

- ◎ narrower step : The image density is increased but the rotational speed is reduced.
- ◎ wider step : The image density is reduced but the rotational speed is increased.



FUNCTION SETTINGS

3. STEP (BOTTOM-SCAN)

◎ The step angle (scanning angle) in the Bottom Scan mode may be selected.

• Highlight the "STEP (BOTTOM-SCAN)" function by means of   keys and select the desired step angle by   keys.



• Each press of   keys changes the angles "3° → 5°" in 180/80kHz frequency and "6° → 12°" in 150kHz frequency.

※ 180/80kHz frequencies

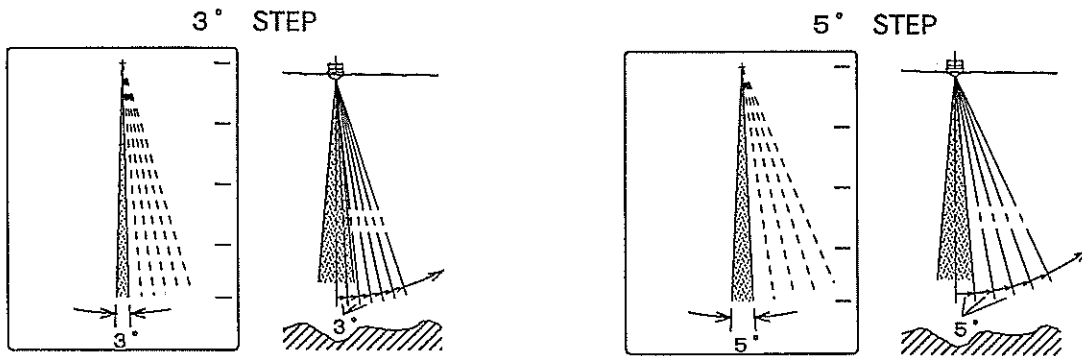



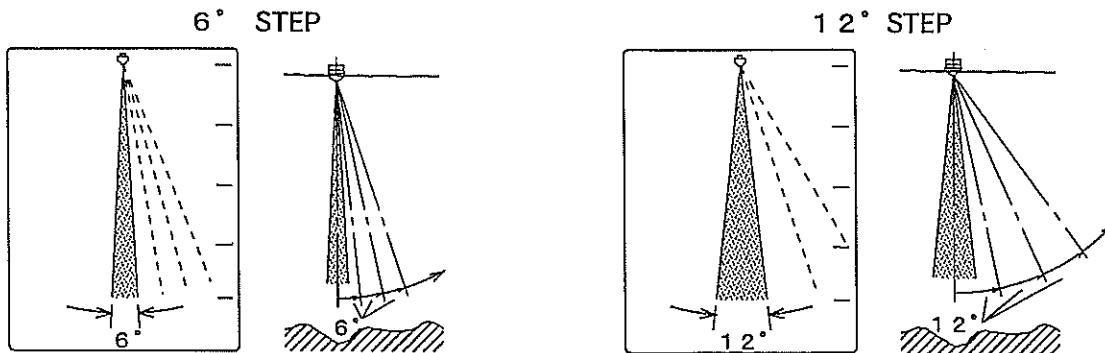

※ 150kHz frequency



4. OFF-CENTER POSITION

⊙ The ship's position on the screen may be selected in the OFF-CENTER mode (MODE dial 2).

- Highlight the "OFF-CENTER POS." function by means of   keys and select the desired center position by   keys.

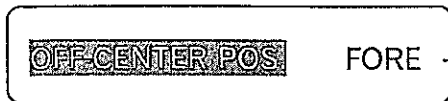



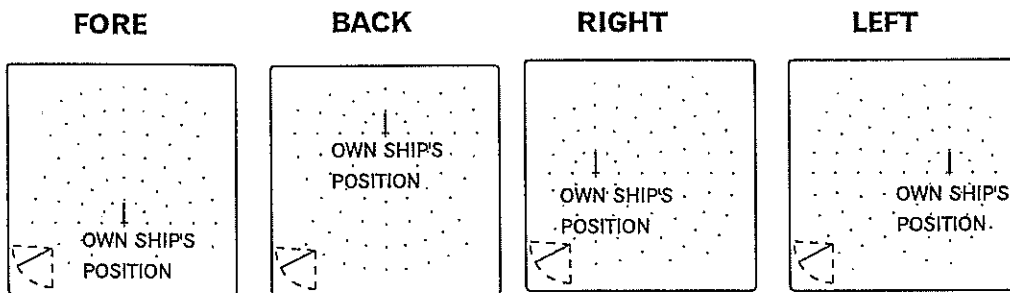

- Each press of  or  key changes the setting "FORE - BACK - RIGHT - LEFT"



5. SCALE DISPLAY

⊙ The scale dots display under SONAR mode can be turned on/off.

- Highlight the "SCALE DOTS" function by means of   keys and select ON or OFF by   keys.



- Each press of  or  key changes the setting, "OFF - ON".

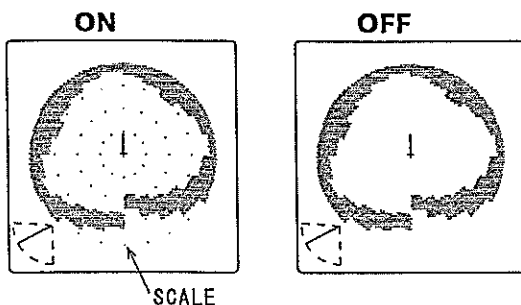





- ON : displays scale (dots).
- OFF : displays no scale.

- When the scale dots display OFF is selected, no scale appears on the screen in SONAR/OFF-CENTER modes. However the scale appears on the screen in BOTTOM SCAN/SOUNDER modes.



FUNCTION SETTINGS

6. COMPASS DISPLAY

◎ The points of the compass can be shown on the screen in the Sonar mode by connecting S-1800 to an external navigator.

- Highlight the "COMPASS DISP." function by means of   keys and select the compass display function ON or OFF by   keys.





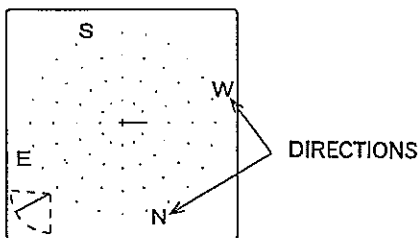

• Each press of  or  key changes the Compass display, "ON - OFF".





- ON : displays the points of the compass.
- OFF : displays no points of the compass.

7. WAKE DISPLAY

◎ The track line can be shown on the screen in the Sonar mode by connecting S-1800 to an external navigator.

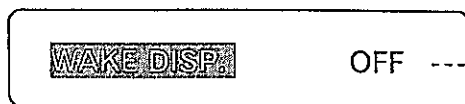
- Highlight the "WAKE DISP." function by means of   keys and select the wake display function ON or OFF by   keys.



• Each press of   keys changes the wake display "ON - OFF".

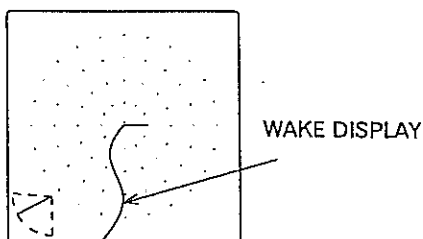

- ON : displays the wake (trackline).
- OFF : displays no wake (trackline).

8. WAKE SUB RANGE

⊙ The screen width scaling for a navigational display can be selected. **[CF]** page 70

- Highlight the "WAKE SUB RANGE" function by means of **[↑]****[↓]** keys and select the screen width by **[←]****[→]** keys.

WAKE SUB RANGE 50m ----- • Each press of **[←]** or **[→]** key changes the values.
"10 - 20 - 30500".

- [→]** : increases the values.
- [←]** : decreases the values.

9. WAKE MEMORY INTERVAL

⊙ The track is saved into memory and its interval can be selected.

- Highlight the "WAKE MEM. INTERVAL" function by means of **[↑]****[↓]** keys and select the interval by **[←]****[→]** keys.

WAKE MEM. INTERVAL 5 SEC. ---- • Each press of **[←]** or **[→]** keys changes the values.
"5 SEC. - 10 SEC. - 30 SEC. - 60 SEC".

10. PRESS RATE (COMPRESSED RATE)

⊙ The rate of the compressed picture can be selected. **[CF]** page 69

- Highlight the "PRESS RATE" function by means of **[↑]****[↓]** keys and select the setting by **[←]****[→]** keys.







PRESS RATE 1 / 4 ----- • Each press of **[←]** or **[→]** key changes the values.
"1 / 2 - 1 / 4 - 1 / 8. - 1 / 16"..

- Compress rate 1/2 shows one line for 2 sound beams and 1/4 for 4 sound beams.

FUNCTION SETTINGS

OTHERS





OTHERS	
RETURN MAIN MENU	
AUDIO LEVEL	0
TARGET LOCK	MODE 1
TRIGGER SIGNAL	INTERNAL
DEPTH UNIT	m
TEMP. UNIT	°C
SPEED UNIT	K t
HOIST AUTO UP	OFF
STABILIZER	OFF
TRAIN CORRECT	0°
PANEL BRIGHTNESS	BRIGHT
COLOR SELECTION	A-1

- Use the cursor selection key  or  to return to MAIN MENU.
- Use the cursor selection key  or  to highlight the item you wish to change.
- Press  or  key to select the desired setting.
The values of TRAIN CORRCET can not be changed here.
CF page 81



No display of "STABILIZER" in 180/80kHz frequencies.

1. AUDIO LEVEL

◎ The sound level of an external speaker can be adjusted.

- Highlight the "AUDIO LEVEL" function by means of   keys and select the desired level by   keys.



- Each press of  or  key changes the level from 0 to 39.

 key : decreases the volume

 key : increases the volume





NOTE !

◎ Please note that "AUDIO LEVEL" function is not available when 45° step is set in Sonar Mode.



◎ Its appropriate speaker is (4 Ω), but it is an optional item. **CF** page 39/41.

FUNCTION SETTINGS

2. TARGET LOCK

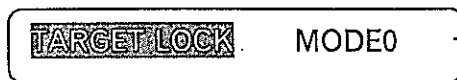
- ◎ This function changes the rotary direction or tracks the target automatically.
- To select the desired Target Lock function when  key is pressed during the Searchlight operation in the Sonar mode.
- Highlight the "TARGET LOCK" function by means of   keys and select the desired TARGET LOCK function by   keys.



- Each press of  or  key changes the setting "MODE0 - MODE1 - MODE2 - MODE3"

- The below explained "TARGET LOCK" function ②-③ and ④ in the next page is not available when 45° step is set in 150kHz Sonar Mode.

① MODE 0

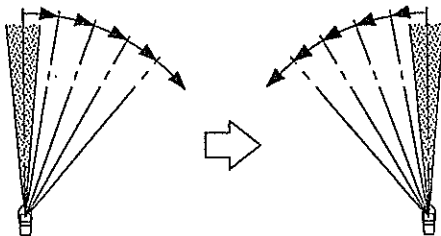

- When MODE 0 is selected as a target lock mode, the sector rotary direction is reversed by pressing  key.
- Not tracking the echo automatically.

② MODE 1

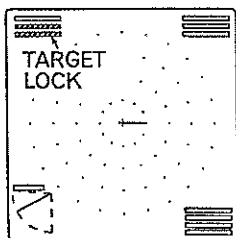

- When MODE 1 is selected as a target lock mode, by pressing  key the Sonar beam will track the echo automatically left and right and "TARGET LOCK" will be displayed at the top left of the screen. If the beam should have lost the echo and not picked it up again after a 60° sweep, the Target Lock function will be released.

③ MODE 2

- When MODE 2 is selected as a target lock mode, the Sonar beam will track the echo automatically up and down (one time of up and down track after three times of left and right track) in addition to the Mode 1 functions.

<To be continued>

④ MODE 3

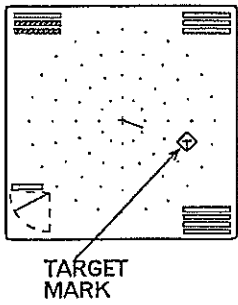

- When S-1800 is connected to a navigator, the Target Mark is displayed and tracked automatically by pressing the Target Lock key .





The Target Mark follows after the ship automatically and moves on the screen. This Target Mark also displayed on the Sub-Display in the split screen.

NOTE !

- ECHO CONFIRMATION: Under Target Lock the Sonar beam will track the strongest echo from 1/4 of the scale (in Off Center mode 1/6 of the scale) or when the strongest echo of the Historical Display is 3 pixels or more.
- During Target Lock operation Tilt, Bearing and Sector keys will not be operated, and if the Menu or Range keys are pressed or the Display mode is changed Target Lock will be released.
- When Target Lock ceases Bearing and Sector angles will return to their original positions, Tilt angle will remain in Target Lock position.
- Target Lock function is not available in the Bottom Scan Mode.

3. TRIGGER SIGNAL

- To select where the trigger signal is taken from either INTERNAL or EXTERNAL.

- Highlight the "TRIGGER SIGNAL" function by means of   keys and select the desired trigger signal by   keys.



- Each press of  or  key changes the setting "INTERNAL - EXTERNAL"





- INTERNAL : selects the signal of the S-1800.
- EXTERNAL : selects the signal from an external unit.



NOTE !

- To synchronize the external equipment, the optional kit is required.
In case of "INTERNAL" selection the receptacle for the trigger signal output is on the control unit panel of S-1800.  page 36/37

4. DEPTH UNIT

- ⊙ The user may select the displayed depth unit to be one of the following:
meters (m), braccia (br), fathoms (fm) or feet (ft).





- Highlight the "DEPTH UNIT" function by means of   keys and select the desired depth unit by   keys.



 • Each press of  or  key changes the Depth unit.
" m - br - fm - ft "

- | | | | |
|----|--|----|--|
| mt | : Displays the unit meters. | br | : Displays the unit braccia. 1BR : 1.65m |
| ft | : Displays the unit fathoms. 1FM : 1.8288m | ft | : Displays the unit feet. 1FT : 0.3048m |

5. TEMPERATURE UNIT

- ⊙ Temperature unit can be set to °C or °F.





- Highlight the "TEMP. UNIT" function by means of   keys and select the desired temperature unit by   keys.



 • Each press of  or  key changes the temperature unit "°C - °F "

- | | |
|----|--------------|
| °C | : centigrade |
| °F | : Fahrenheit |

6. TEMPERATURE ADJUSTMENT

- ⊙ To adjust the water temperature displayed on the screen.

- Highlight the "TEMP. ADJUST" function by means of   keys and select the range to display an adjusted temperature by   keys.





 • Each press of  or  key changes the range in 0.1 interval from - 9.9 to + 9.9.

- | | | | |
|---|---------|---|---|
| { | + 9.9 ° | : maximized the value of the adjustment | ↑  increases the value |
| | + 0.0 ° | : no adjustment | |
| | - 9.9 ° | : minimized the value of the adjustment | |



FUNCTION SETTINGS

7. SPEED UNIT

◎ It can be shown in knots (kt) or kilometers/hour (km/h).

- Highlight the "SPEED UNIT" function by means of   keys and select the speed unit by   keys.







..... Each press of  or  key changes the speed unit, " kt - km/h ".



- kt : measured in knot.
- km/h : measured in kilometers.



8. HOIST AUTO UP



◎ The soundome can be retracted automatically when the ship speed is over a specified speed by connecting to an external equipment.

- Highlight the "HOIST AUTO UP" function by means of   keys and select the value by   keys.





..... Each press of  or  key changes the item, "OFF or 10 kt (18 km/h).

- Use the Tilt Key  or  to change the speed after selecting the initial value 10 kt (18 km/h). Selectable values : "1 kt ~ 15 kt" or "1 km/h ~ 27 km/h)

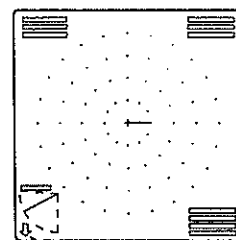
- Tilt Key  : increases the value
- Tilt Key  : decreases the value







SHOWS THE SOUNDOME POSITION, LOWERING RAISING.



- Soundome position mark shows the down direction  on the left bottom of the screen while the soundome is lowering. When Hoist Auto UP function is activated, the mark changes into . The Hoist Down Light  (Sensor) goes off when the soundome is retracted automatically.

※ We recommend the ship speed below 15kt (27km/h) in 180/80kHz and 10kt in 150kHz while retracting.

9. **STABILIZER** (in 150kHz frequency only)

◎ By connecting a clino meter - an inclination sensor (OP-120), the influence by the shake of ships, such as pitching and rolling, can be suppressed.





- Highlight the "STABILIZER" function by means of   keys and select "ON" by   keys.



 Each press of  or  key changes the item, "ON" or "OFF".

- ON : activates stabilizer function.
- OFF : not activate stabilizer function.

10. **TRAIN CORRECT**

◎ To adjust the deviation of the bow direction (0°).

- In the Sonar mode use  or  key to set the Bearing toward Bow direction.
- Select MENU 2/OTHERS and highlight the "TRAIN CORRECT" function by means of   keys.

 Each press of  or  key changes the degree of Train Correct.

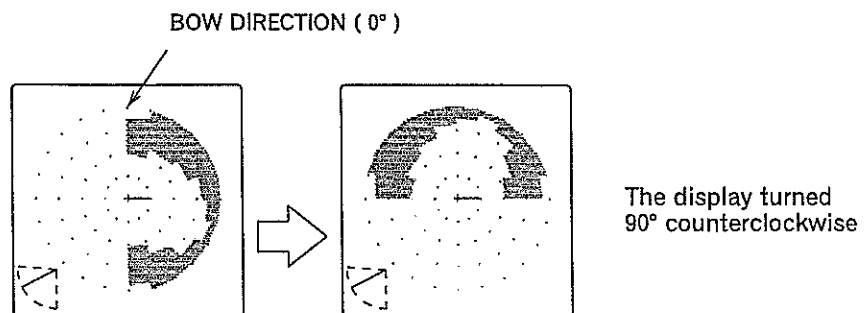





- When releasing this function, set the current Bearing at 0° and follow the above procedure "TRAIN CORRECT" again.

FUNCTION SETTINGS



11. PANEL BRIGHTNESS

◎ To adjust the intensity of the sonar display (backlight) .

For nighttime view, Suzuki recommends "DARK".





- Highlight the "PANEL BRIGHTNESS" function by means of   keys and select "BRIGHT" or "DARK" by   keys.





- Each press of  or  key changes the item "BRIGHT" or "DARK" .

12. COLOR SELECTION

◎ The display background color may be selected from four set options A-1, A-2, B-1, B-2 or the tone range may be specified freely on C-1, C-2 in Color Palette function.

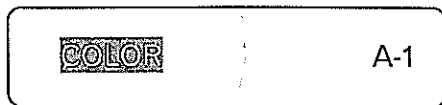





- C-1 and C-2 can be customized to suit individual needs and wishes.
- The initial settings for C-1, C-2 are C-1=A-1, C-2=B-1.
- Highlight the "COLOR" function by means of   keys and select the desired tone by   keys.

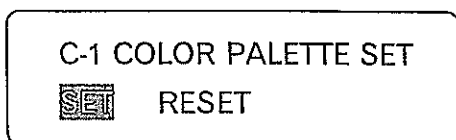

- Each press of  or  key changes the tone, " A-1, A-2, B-1, B-2, C-1, C-2 " .





* GUIDES TO THE COLOR PALETTE.







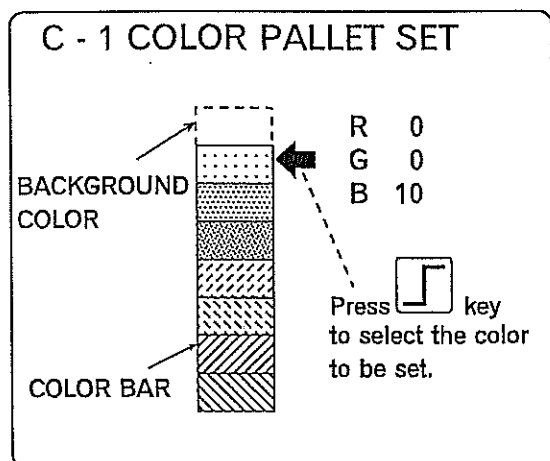

- Use   keys to select C-1 or C-2.
- Press  key to display the menu on the left.
- Highlight the "RESET" function by means of   keys and press  key to return to the initial setting and the Palette Setting Menu terminates.

<To be continued>

FUNCTION SETTINGS

- Highlight the "SET" function by means of   keys and press  key to activate the following menu.
- Press  key to select the desired color.
- By using  key to move the arrow to the desired frame, the menu to set the color tone selected in step 3 (red • green • blue) is displayed.



- Highlight a color to be set by means of   keys and select the level of the color (0 ~ 15) by   keys.
- The number 15 is the strongest color and its tone decreases in accordance with the smaller number
- Press  key to memorize the desired color selection into "C - 1" or "C - 2" .

COLOR PALLET

- By using Color Palette function by changing the ratio of red, green, blue of the colors on the display sample various tones may be selected.
- By using Color Palette function the strength of each of the three colors (red, green, blue) may be set in 15 steps freely.
- The Color Palette function may be used to set the tones according to the target fish species so as to produce the most visible display.

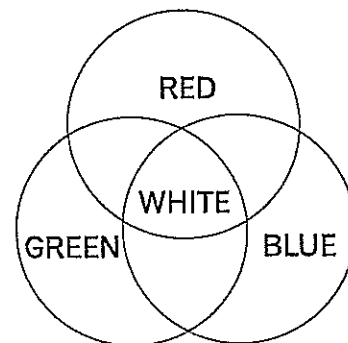

Chapter 5

SONAR OPERATION

This chapter provides you the description of operation dials and keys for the S-1800 Sonar.

OPERATION DIAL	DISPLAY MODE DIAL -----	85
	RANGE SETTING DIAL -----	85
	SECTOR DIAL -----	86
	BRIGHTNESS DIAL -----	87
	GAIN DIAL -----	87
	FAR GAIN DIAL -----	87
OPERATION KEY	POWER ON/OFF KEY -----	88
	HOIST KEYS -----	88
	HOIST DOWN LIGHT -----	88
	BEARING KEY -----	89
	TILT KEY -----	90
	CURSOR KEYS -----	91
	TARGET LOCK KEY -----	93
	MARK KEY -----	94
	THRESHOLD KEY -----	94
OPERATION MODE KEYS -----	95	

OPERATION DIALS

MODE DIALS

☉ Selects the Displayed Mode.

- All operational functions displayed in the right split screen (**CF** page 67) and own ship's position on OFF-CENTER screen (**CF** page 73) are accessed by using "MENU 2".

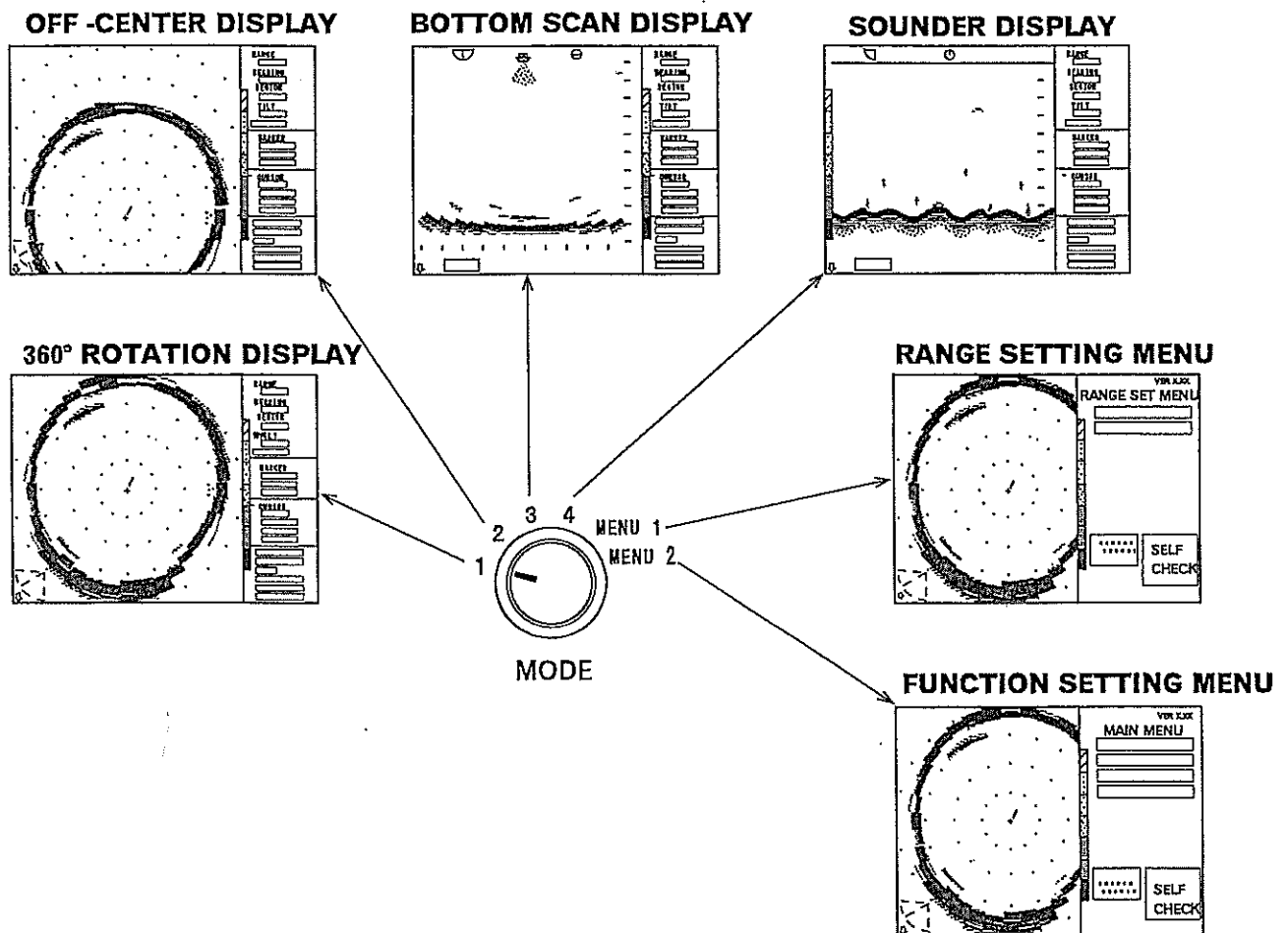

RANGE DIALS

☉ Changes the basic range (basic depth).

- The setting for 8 ranges is accessed by using "MENU 1". **CF** page 57
- The setting for the depth units is accessed by using "MENU 2". **CF** page 79
- Scale marker can be turned on or off by using "MENU 2". **CF** page 73

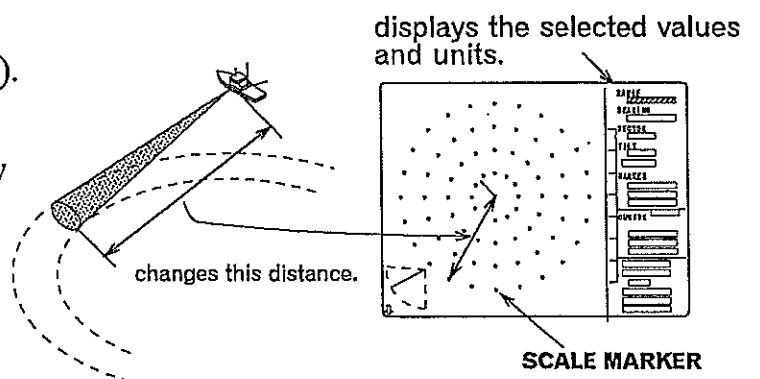

OPERATION DIALS

SECTOR DIALS

- ⊙ Changes the scanning historical angle (sector angle) in the Sonar Mode.
- ⊙ Changes the scanning secotr angel (vertical angle) in the Botom Scan Mode.

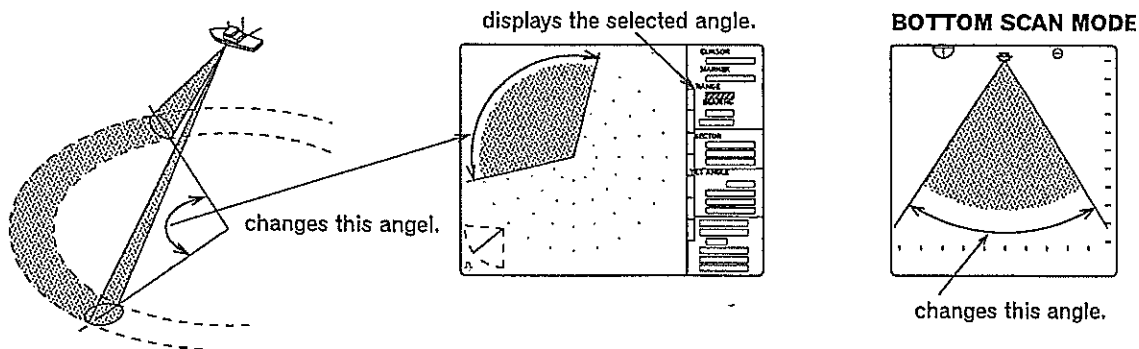

- Clockwise rotation (→●) widens the sector angle and counterclockwise rotation (→⊙) narrows the sector angle.
- Refer to the following list for the step angle for each frequency.
The setting for the step is accessed by using "MENU 2". page 71/72

※ SELECTABLE SECTOR ANGLE FOR 180/80kHz

SONAR MODE OPERATION

5° STEP	5°	25°	45°	85°	125°	165°	205°	360°
10° STEP	10°	30°	50°	90°	130°	170°	210°	360°

BOTTOM SCAN MODE OPERATION

3° STEP	3°	27°	45°	63°	93°	117°	147°	177°
5° STEP	5°	25°	45°	65°	95°	115°	145°	175°

※ SELECTABLE SECTOR ANGLE FOR 150kHz

SONAR MODE OPERATION

45° STEP	45°	135°	225°	315°	360°	(SECTOR SCAN)		
6° STEP	6°	30°	54°	102°	150°	198°	246°	360° (6° SEARCHLIGHT)
12° STEP	12°	36°	60°	108°	156°	204°	252°	360° (12° SEARCHLIGHT)
18° STEP	18°	54°	90°	126°	162°	198°	234°	360° (18° SEARCHLIGHT)

BOTTOM SCAN MODE OPERATION

6° STEP	6°	30°	54°	78°	102°	126°	150°	174° (6° SEARCHLIGHT)
12° STEP	12°	36°	60°	84°	108°	132°	156°	180° (12° SEARCHLIGHT)

ON/OFF BRIGHTNESS DIAL



- ⊙ Clockwise turning: increases the screen brightness and "10" is the brightest.
- The brightness of the control panel can not be adjusted here. It can be adjusted by "MENU 2 ". **CF** page 82

GAIN DIAL

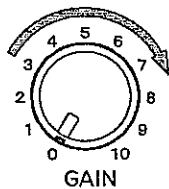

- ⊙ Adjusts the sensitivity of the received signal.
- Gain controls can be adjusted by "GAIN UP" function in "MENU 2". **CF** page 61

FAR GAIN DIAL

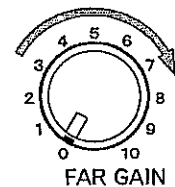

- ⊙ **TVG CURVE in MENU 2**
 - 180/80kHzOFF ~ 40 LOG
 - 150kHz..... 10 LOG ~ 40 LOG

As the echoes returning from the bottom and from fish targets get weaker as the depth increase it is advantageous to have a Time Variable Gain that automatically compensates for the loss in signal strength. **CF** page 62



- ⊙ **STC function in TVG CURVE in 150kHz**



This STC function is to suppress the receiver gain immediately below the transducer and gradually restores it with distance. When the Far Gain Dial is turned counterclockwise, the intensity of the receiving signal decreases gradually with the increase in distance.
- Selecting STC function releases the gain adjustment automatically
- Gain controls can be adjusted by Gain Dials and "GAIN UP" function in MENU 2 for all conditions the operator will encounter, ensuring accurate target presentation. **CF** page 62

OPERATION KEYS

POWER ON/OFF KEY

- ◎ To turn on the power, press  key.

When power is applied, the soundome lowers automatically and the following will occur.

- The Hoist Down Light-sensor lamp () is lighted on.
- The sensor lamp mark () appears on the left down of the screen.
- The sign "WAITING" appears on the middle of the screen while lowering the soundome and then start to operate.





- ◎ To turn off the power, press  key for a while.

When power is turned off, the soundome raises automatically and the following will occur.

- The Hoist Down Light-sensor lamp  is lighted off when the soundome is completely uploaded in the trunk.
- Not turn off the power of the hoist until the sensor lamp is lighted off.

HOIST KEYS

- ◎ The hoist keys raise and lower the soundome.

- Pressing  key during the sonar operation raises the soundome and the mark on the screen changes into  . The sensor lamp is lighted off when the soundome is completely uploaded in the trunk.
- Pressing  key lowers the soundome and the mark on the screen changes into  . The sensor lamp is lighted on.
- Slow down the ship's speed before pressing  key in case of lowering the soundome again after the uploading it automatically.

SENSOR LAMP

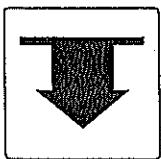

SENSOR

- ◎ The soundome is lowering while this sensor lamp is lighted on. Not turn off the power of the hoist while this lamp is lighted on.

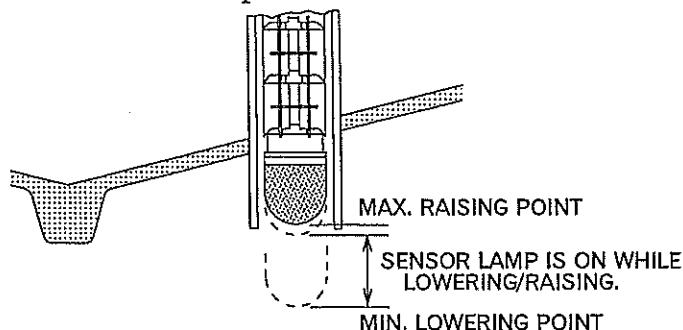

BEARING KEYS

☉ Use these keys to define the center of current scanning sector in Sonar Mode.

- The bearing angle of the display is shifted with every 5° steps in 180/80kHz frequencies.
- The bearing angle of the display is shifted with every 3° steps in 150kHz frequency.

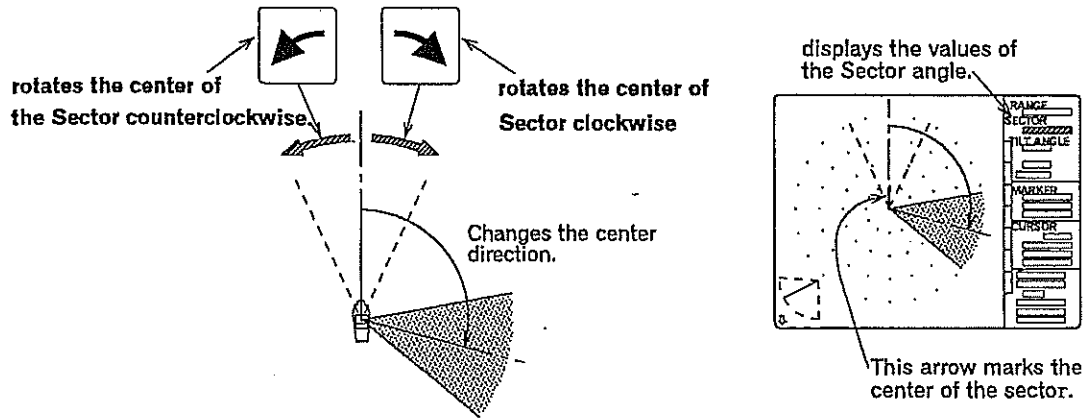

☉ Use these keys to define the center of current scanning sector in Bottom Scan Mode.

- The bearing angle of the display is shifted with every 5° steps in 180/80kHz frequencies.
- The bearing angle of the display is shifted with every 3° steps in 150kHz frequency.

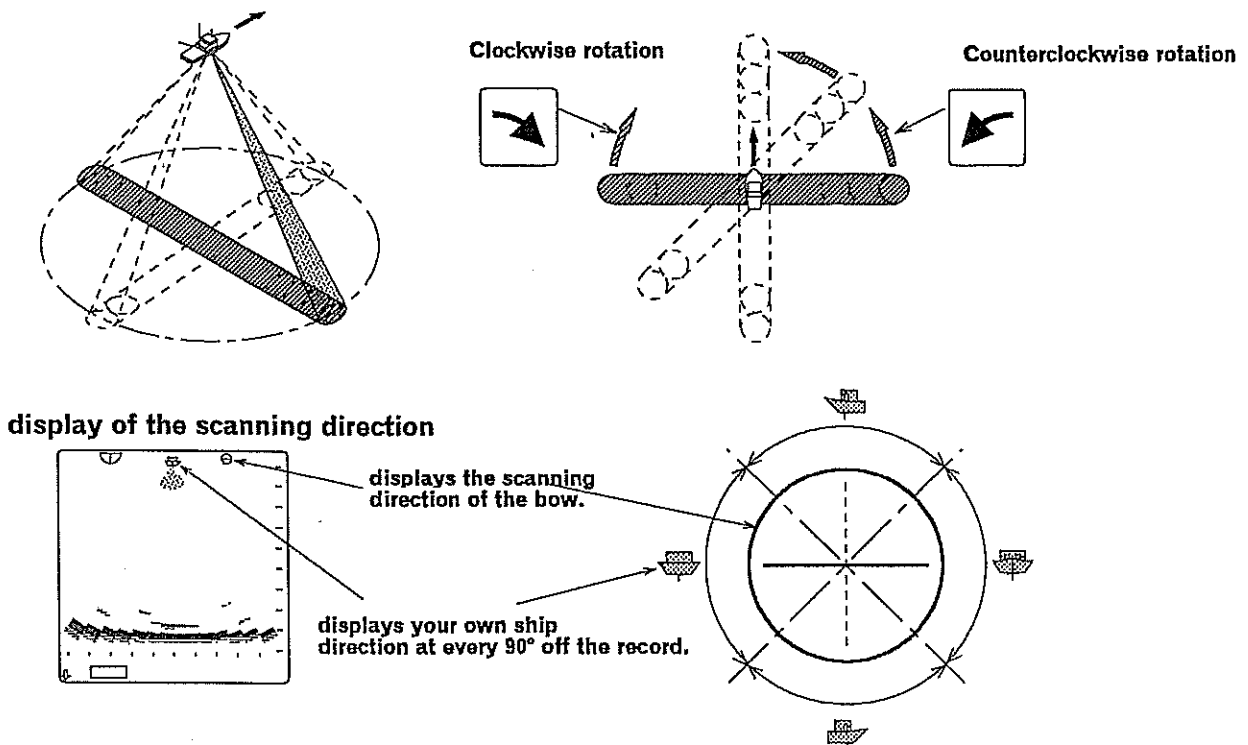

☉ In case of Sounder Mode "TILT KEYS" explained in the next page is collaborated with the bearing keys. The shifted angles are the same as those of Bottom Scan Mode.

CF page 90

OPERATION KEYS

TILT KEYS

⊙ Use these keys to control the tilt angle in the Sonar Mode.

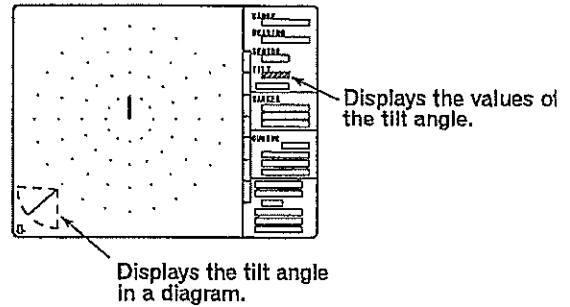
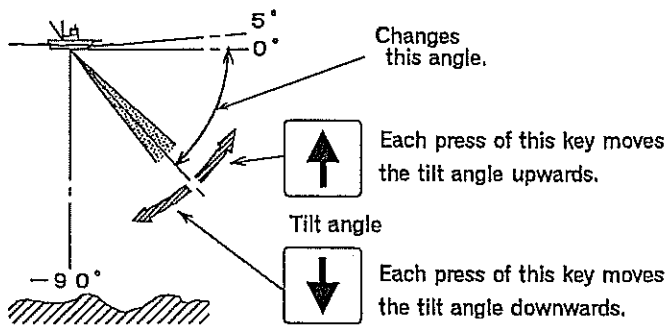

VARIABLE TILT ANGLE : $5^{\circ} \sim 0^{\circ} \sim -90^{\circ}$ (every 1°)

⊙ Use these keys to control the tilt angle in the Bottom Scan Mode.

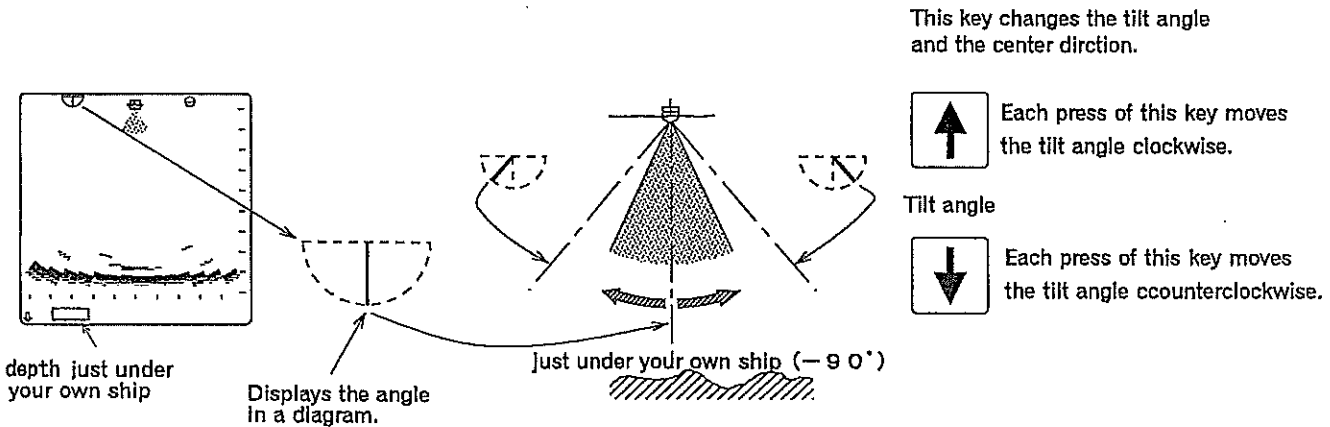

The angle center is just under your own ship.

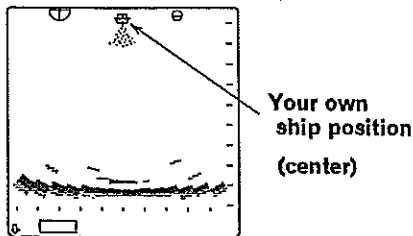

The center is set in the range shown by an arrow.

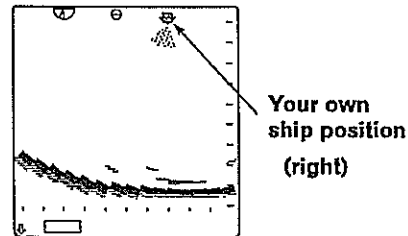

The center is set in the range shown by an arrow.

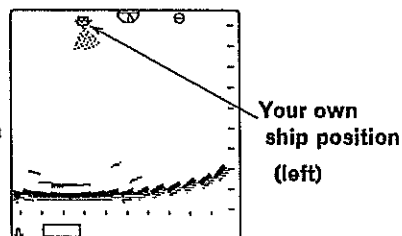

VARIABLE TILT ANGLE



- 180/80kHz : 3° step $-3^{\circ} \sim -90^{\circ}$ (every 3°)
- : 5° step $-5^{\circ} \sim -90^{\circ}$ (every 5°)
- 150kHz : 6° step and 12° step $-6^{\circ} \sim -90^{\circ}$ (every 6°)

※ Refer to the page 72 for steps.

<To be continued>

OPERATION KEYS

- ⊙ After the first installing S-1800 the Ring Marker or the Cross Cursor neither appears nor operates on the screen even if turning on the power or after returning to factory settings.

- First the marker appears by pressing either  or  key and then select the Ring Marker or the Cross Cursor by  key.

The Ring Marker is not available in Sounder Mode.



The inactive function is displayed in red and stored even the power is turned off.

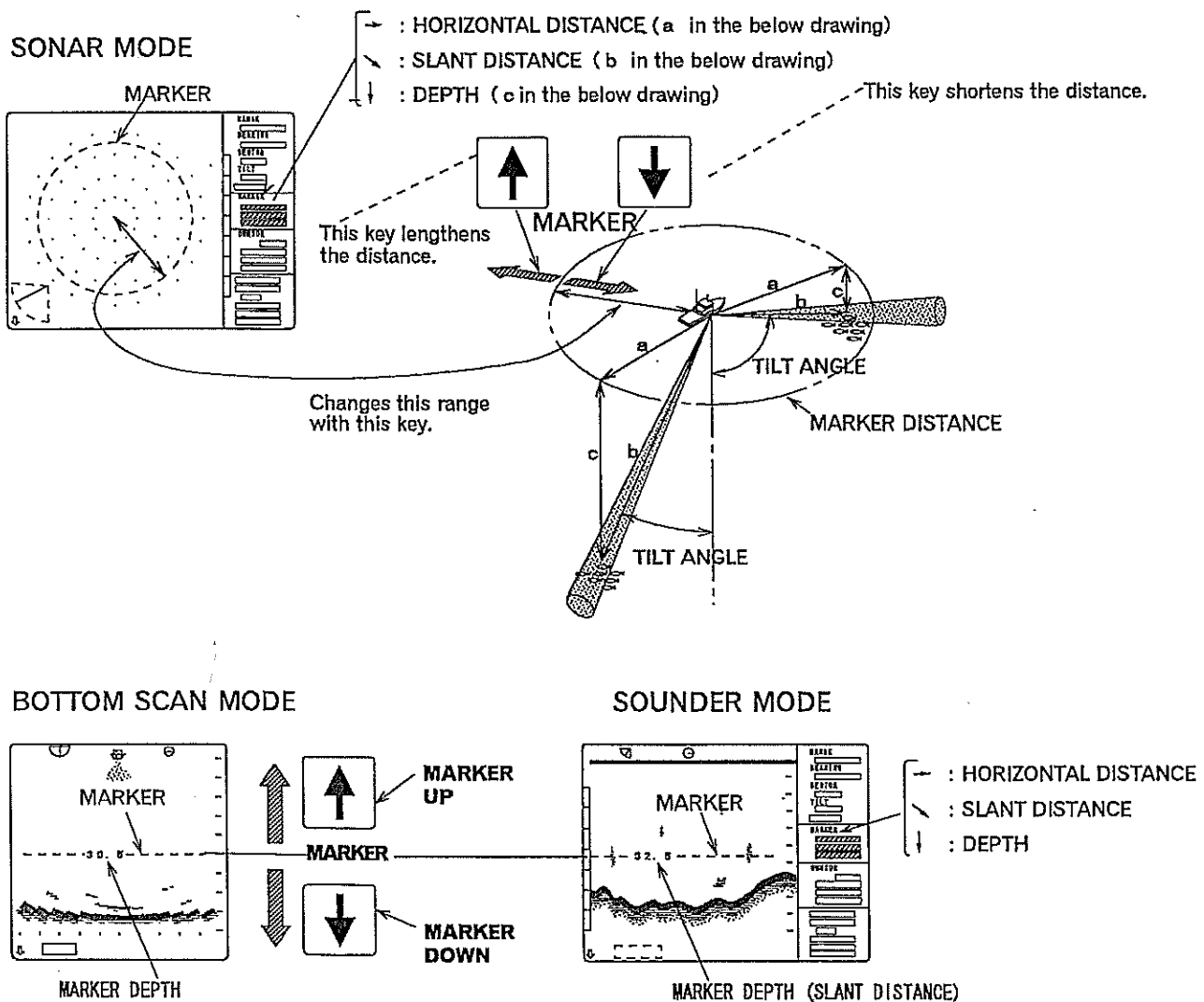

- ⊙ When the Ring Marker is selected, (the Cross Cursor is in red or not displayed)



※ VRM appears and Marker data is not presented right in Bottom Scan Mode.

※ In Sounder Mode it presents the slant distance in the MARKER box.

- Press  and  key at the time to turn the Marker off.

Again pressing  or  key returns Marker to previous position.

- ◎ Use the tilt keys and the bearing keys to define the direction of the detection.

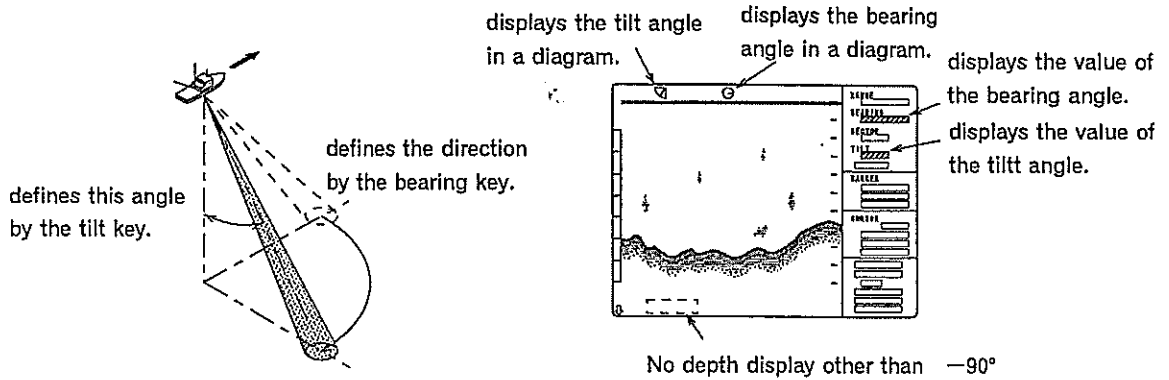











VARIABLE TILT ANGLE : $5^\circ \sim 0^\circ \sim -90^\circ$ (every 1°)

- Marker indicates the depth other than just below the ship (-90°). Refer to the following "CURSOR KEYS" for Maker.





CURSOR KEYS

- ◎ Use these keys to know the depth and horizontal/slant distance to a user selected target.

-  key selects the cursor and     key move cursor in any direction on the screen.

-  key : activates either Ring Marker or Cross Cursor in Sonar Mode.
: activates either VRM or Cross Cursor in Bottom Scan Mode.
: displays VRM only in Sounder Mode.
-  key : expands the Ring Marker, shifts the Cross Cursor upward or shifts VRM to the shallow.
-  key : contracts the Ring Marker, shifts the Cross Cursor downward or shifts VRM to the deeper area.
-  key : shifts the Cross Cursor left
-  key : shifts the Cross Cursor right.

⊙ When the Cross Cursor is selected, (the Ring Marker is in red or not displayed) however it is not available in Sounder Mode.

- Set the Cross Cursor on a target by using     key and the depth and horizontal/slant distance to the target are displayed in the CURSOR box.

SONAR MODE

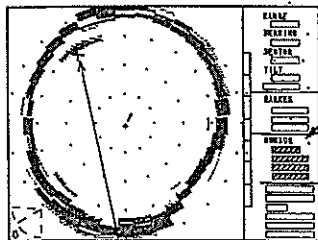

CROSS CURSOR

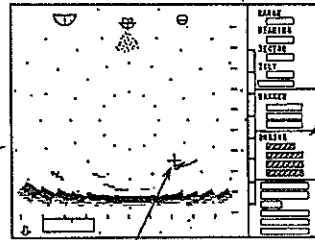

→ : BEARING
 → : HISTORICAL DISTANCE
 ↘ : SLAND DISTANCE
 ↓ : DEPTH

BOTTOM SCAN MODE





CROSS CURSOR

→ : BEARING
 → : HISTORICAL DISTANCE
 ↘ : SLAND DISTANCE
 ↓ : DEPTH

- The Cross Cursor is used for placing the marks ( page 94) and also the target marks for Target Lock ( page 78).

TARGET LOCK KEY

- ⊙ When pressing  (the Target Lock key) in Sonar Mode, the direction of sweep of the Sonar beam is reversed. (when MENU 2 / TARGET LOCK / MODE 0 is selected.)
- ⊙ When pressing  (the Target Lock key) in Sonar Mode, the Sonar beam track the echo automatically. (when MENU 2 / TARGET LOCK / MODE 1 or MODE 2 is selected.) However 45° step in 150kHz frequency is selected, this function is disabled.
- ⊙ By pressing  (the Target Lock key) on the target in Sonar Mode the target mark is displayed and tracked automatically. (when MENU 2 / TARGET LOCK / MODE 3 is selected.) However 45° step in 150kHz frequency is selected, this function is not disable.

- Make reference to Target Lock function on page 77 .

NOTE !

- ⊙  Target Lock key is disabled in Bottom Scan Mode and Sounder Mode.

OPERATION KEYS

MARK KEY

⊙ The mark can be placed on the screen in Sonar Mode.

By placing the Cross Cursor on a marked target and pressing  key is displayed the mark (◇) on the screen.

- The mark moves on the screen being accompanied by the ship's movement.
- Wake Display on (DISP ITEM SEL./WAKE DISP./ON) is selected in the split screen, the mark is also displayed there.

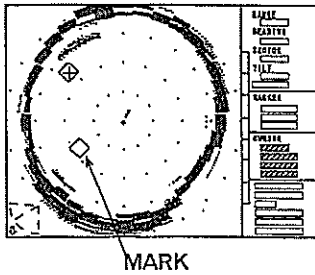

THRESHOLD KEY

⊙ The weak echoes disappear by pressing this key accordingly.

- Only strong wanted targets appear on the screen by pressing this key to erase unwanted returns such as plankton or noise.
- Each press of  key clears the weakest color sample.

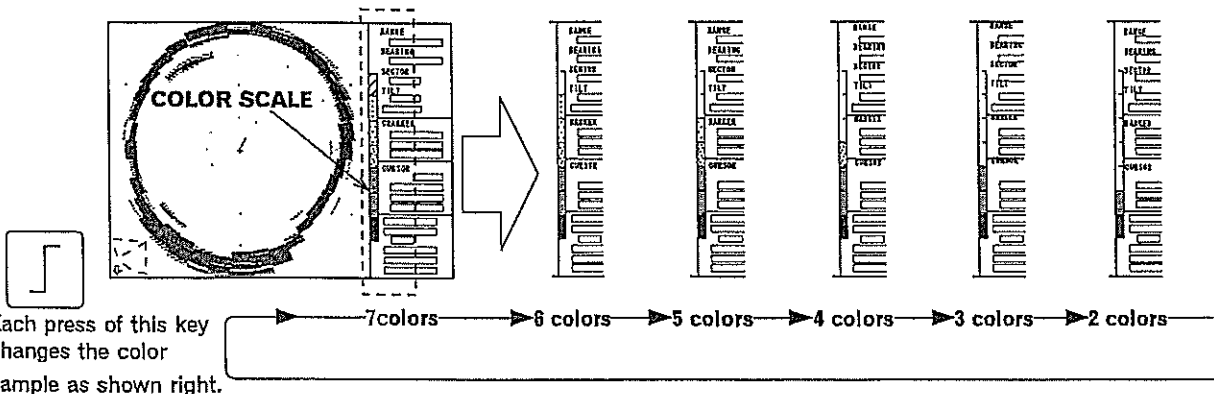

OPERATION KEYS

OPERATION MODE KEYS

◎ Use these keys to select one of the 3 kinds of operation mode you have created.

By pressing one of these keys the desired operation mode can be set immediately.

• "OPERATION SET MENU" is accessed by selecting MENU 2 and then pressing () key.

• Highlight the item to be changed by means of keys and set the desired values by keys.

• To return back to the previous operation mode, use MODE dial.

OPERATION MODE 1 (2,3)	
STEP (SONAR)	10°
STEP (BOTTOM-SCAN)	5°
BEARING (SONAR)	0°
BEARING (BOTTOM-SCAN)	270°
TILT (SONAR)	0°
TILT (BOTTOM-SCAN)	- 90°
GAIN UP	OFF
TVG CURVE	30LOG

• Press key to set the desired values.

• By pressing one of the operation mode () keys the desired "Operation Mode" appears on the screen instantly.

• The settings of Operation modes would not be changed, even if other settings are selected on the control panel or MENU 2. During the operation by one of the operation modes the settings can be changed and activate the changed settings, however pressing one of the operation keys () again returns to the previous operation mode.

NOTE !

◎ It is possible to memorize the present settings in the operation modes without displaying "Operation Mode".

• Hold the () key for three seconds after the first buzzer. By the second buzzer the present settings are memorized in the Operation Mode.

• Note that it may not be memorized when the key is released before the second buzzer.

Chapter 6

OPTION

This chapter provides you the explanation related to the optional terminal kits.

OPTIONAL CONNECTIONS

- ◎ The S-1800 is designed to interface with various types of external equipment that output or accept data signals in the NMEA sentences or the remote controller.

The connection cables between the main unit and others are not included.

P. No.	NAME	TERMINAL CONNECTIONS
0P-277	REMOTE CONTROLLER	
0P-305	N A V - I N TERMINAL (INTERFACE KIT FOR NAVIGATIONAL DEVICE)	No1:Signal Input + No3: Shield No4:Signal Output + No2:Signal Input - No5:Signal Output -
0P-320	V G A OUTPUT TERMINAL (INTERFACE KIT FOR CONNECTION OF EXTERNAL VGA MONITOR)	No1 :Red Output No6 : Red GND No13:H - SYNC No2 :Green Output No7 :Green GND No14: V - SYNC No3 :Blue Output No8 :Blue GND No5 :GND No10: GND Other No: N C
0P-322	TRIGGER INPUT TERMINAL (INTERFACE KIT FOR EXTERNAL TRIGGER)	No1:Trigger Input No2:GND
0P-326	N M E A OUTPUT TERMINAL (INTERFACE KIT FOR NMEA-OUT)	No1:NC No3: Shield No5:Signal Output - No2:NC No4:Signal Output + No6: N C

※ NC.....Nothing to be connected.

HOW TO CONNECT INTERFACING KITS

- ⊙ Before connecting optional kits, remove all cables on the rear panel of the main unit.
- ① Remove the total 8 screws that connect the case cover and the rear panel.
(Point A in the drawing)
- ② Remove the total 4 tapping screws that connect the case cover and the front case and pull the case cover into the direction of the rear panel.

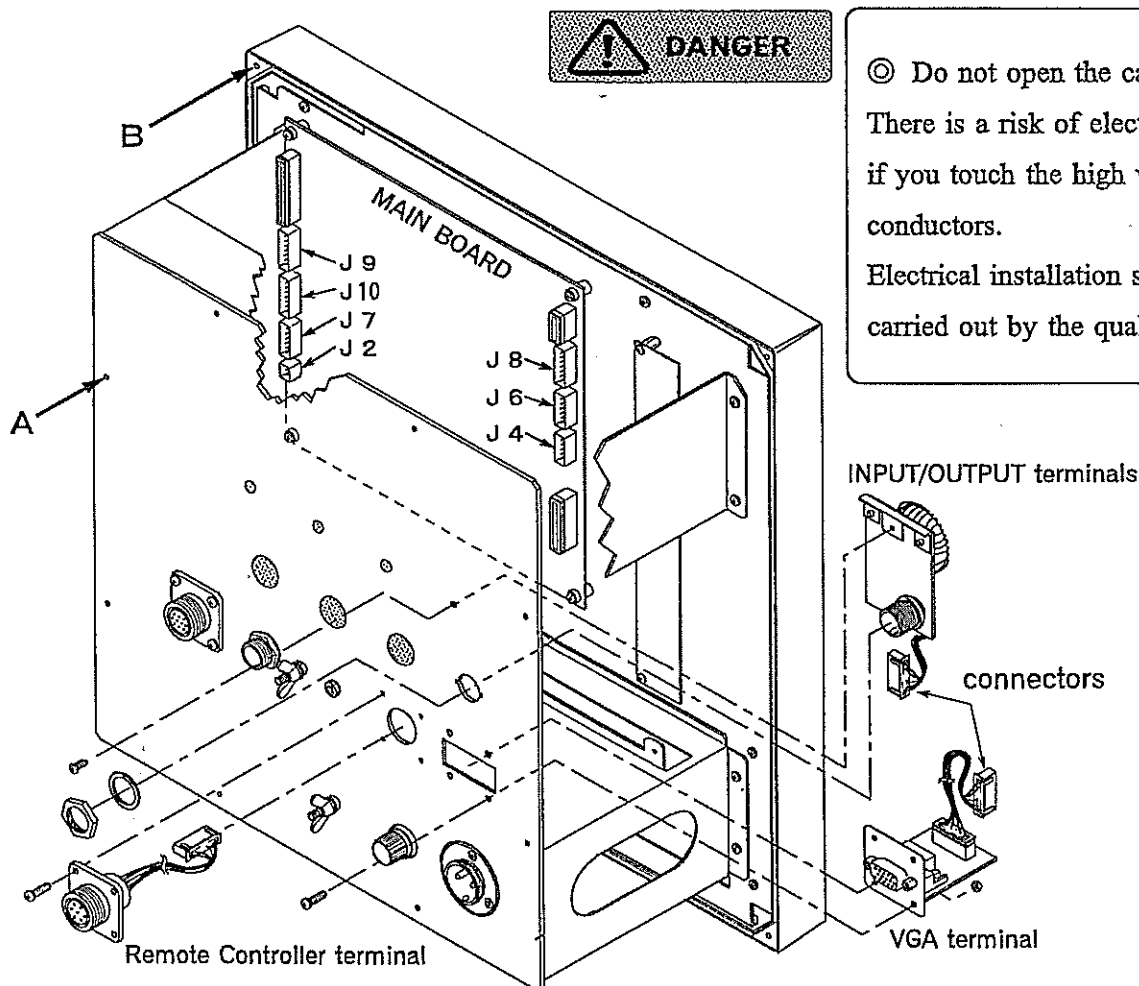

- ③ Remove the cap where the interface kit is connected and attach it as shown in the drawing above.
- ④ Insert the connectors into the specified terminalson the main board.
 - NAV-IN terminal → **J4**
 - NMEA Ouput terminal → **J6**
 - VGA Output terminal → **J10**
 - Trigger Input terminal → **J2**
 - Remote Controller connection → **J7**
- ⑤ Fasten the bolts to fix the case cover.

SPECIFICATIONS

SPECIFICATIONS

◎ DISPLAY CABINET

MODEL NAME	S-1800 M10
Display Presentation	10.4 " LCD (TFT) color 640 (H)x480(V) pixel
Power Supply	10.5 ~ 40 VDC 24W (24V use)
Weight	7 kg (included INSTALLATION BRACKET and MOUNTING PLATE)
Sonar Type	Searchlight Sonar (180/80kHz frequencies) Sector Scanning Sonar / Searchlight Sonar (150kHz frequency)
Display Range	Selectable 8 positions shown in the following page.
Search Sector Angle (Sonar Mode)	<ul style="list-style-type: none"> • 180kHz or 80kHz (5° step) 5° · 25° · 54° · 85° · 125° · 165° · 205° · 360° (10° step) 10° · 30° · 50° · 90° · 130° · 170° · 210° · 360° • 150kHz (45° step) 45° · 135° · 225° · 315° · 360° (6° step) 6° · 30° · 54° · 102° · 150° · 198° · 246° · 360° (12° step) 12° · 36° · 60° · 108° · 156° · 204° · 252° · 360° (18° step) 18° · 54° · 90° · 126° · 162° · 198° · 234° · 360°
(Bottom Scan Mode)	<ul style="list-style-type: none"> • 180kHz or 80kHz (3° step) 3° · 27° · 45° · 63° · 93° · 117° · 147° · 177° (5° step) 5° · 25° · 45° · 65° · 95° · 115° · 145° · 175° • 150kHz (6° step) 6° · 30° · 54° · 78° · 102° · 126° · 150° · 174° (12° step) 12° · 36° · 60° · 84° · 108° · 132° · 156° · 180°
Bearing Center	selectable in step of 5° in 180kHz or 80kHz selectable in step of 3° in 150kHz
Tilt Angle Range	5° ~ 0° ~ - 90° (1° step)
Display Modes	Sonar Mode · Off-center Mode · Bottom Scan Mode · Sounder Mode
Data Display	Range · Range Scale · Tilt Angle · Tilt Angle Diagram · Sector Angle Display · Bearing Angle · Interference Reduction Ring Marker (Historical distance, Slant distance, depth) Cross Cursor (Bearing, Historical distance, Slant distance, Depth) Compass display* · Wake Display* · Ship Speed* · LAT/LON Gain Up · TVG Graph · Color Scale · Temperature · Scan Display (2 types) Own Ship Position · VRM · Depth (on detecting just below the ship)
Other Functions	Operation Modes (3 types) · Off Center, Mark · Mark · Train Correct Target Lock (in Searchlight Mode) · Temperature Adjustment Pulse Width · Color Palette · Gain Control · TVG Control · Dynamic Range Threshold Control · Output Power Reduction · External Trigger Sync. Trigger Signal Output · Hoist Sensor lamp · Hoist Auto Up · Audio Output Gain, Far Gain and Brightness Control Stabilizer (on connecting to the sensor in 150kHz frequency)
Input Data*	NMEA-0183 · Trigger Signal · Remote Controller
Output Data*	LAT/LON for the target · VGA · Trigger Signal

* Optional interface required.

RANGE POSITIONS

180kHz or 80kHz

RANGE	MT			BR·FM			FT		
	NORMAL	OFF-CENTER	BOTTOM-SCAN	NORMAL	OFF-CENTER	BOTTOM-SCAN	NORMAL	OFF-CENTER	BOTTOM-SCAN
1	--	--	10	--	--	6	--	--	40
2	--	--	15	--	--	9	--	--	60
3	20	30	20	12	18	12	80	120	80
4	40	60	40	20	30	20	100	150	100
5	60	90	60	30	45	30	120	180	120
6	80	120	80	40	60	40	160	240	160
7	100	150	100	50	75	50	200	300	200
8	120	180	120	60	90	60	240	360	240
9	140	210	140	80	120	80	280	420	280
10	160	240	160	100	150	100	320	480	320
11	180	270	180	120	180	120	360	540	360
12	200	300	200	160	240	160	400	600	400
13	240	360	240	200	300	200	500	750	500
14	280	420	280	240	360	240	600	900	600
15	320	480	320	280	420	280	700	1050	700
16	360	540	360	320	480	320	800	1200	800
17	400	600	400	360	540	360	900	1350	900
18	500	750	500	400	600	400	1000	1500	1000
19	600	900	600	500	750	500	1200	1800	1200
20	700	1050	700	600	900	600	1600	2400	1600
21	800	1200	800	700	1050	700	2000	3000	2000
22	900	1350	900	800	1200	800	2400	3600	2400
23	1000	1500	1000	900	1350	900	3200	4800	3200
24	1200	1800	1200	1000	1500	1000	4000	6000	4000
25	1600	2400	1600	1200	1800	1200	5000	7500	5000
26	2000	3000	2000	1600	2400	1600	6000	9000	6000

150kHz

RANGE	MT			BR·FM			FT		
	NORMAL	OFF-CENTER	BOTTOM-SCAN	NORMAL	OFF-CENTER	BOTTOM-SCAN	NORMAL	OFF-CENTER	BOTTOM-SCAN
1	40	60	40	20	30	20	120	180	120
2	60	90	60	40	60	40	160	240	160
3	80	120	80	60	90	60	200	300	200
4	100	150	100	80	120	80	240	360	240
5	120	180	120	100	150	100	280	420	280
6	160	240	160	120	180	120	320	480	320
7	200	300	200	160	240	160	400	600	400
8	240	360	240	200	300	200	600	900	600
9	280	420	280	240	360	240	800	1200	800
10	320	480	320	280	420	280	1000	1500	1000
11	400	600	400	320	480	320	1200	1800	1200
12	600	900	600	400	600	400	1600	2400	1600
13	800	1200	800	600	900	600	2400	3600	2400
14	1000	1500	1000	800	1200	800	3200	4800	3200
15	1200	1800	1200	1000	1500	1000	4000	6000	4000
16	1600	2400	1600	1200	1800	1200	5000	7500	5000
17	2000	3000	2000	1600	2400	1600	6000	9000	6000

SPECIFICATIONS

◎ HULL UNIT - CONTROL UNIT

Model Name	S-1800 H180	S-1800 H80
Frequency	180kHz	80kHz
Sonar Type	Searchlight Sonar	
Hoist Stroke	200 ~ 400 m m	
Hoist Time	10 seconds (400 m m stroke, 24V power supply) Lowering or Raising automatically	
External Output	Trigger Signal	
Power Supply	10.5 ~ 30 VDC 110W	
Weight	Hull unit: 44kg (trunk pipe exclusive)	

Model Name	S-1800 H150	
Frequency	150kHz	
Sonar Type	Sector Scanning Sonar / Searchlight Sonar	
Hoist Stroke	200 ~ 400 m m	
Hoist Time	10 seconds (400 m m stroke, 24V power supply) Lowering or Raising automatically	
External Input	Transducer Stabilizer (when optional Sensor is connected)	
External Output	Trigger Signal	
Power Supply	20 ~ 30 VDC 110W (65W on raising)	
Weight	Hull unit: 50.5kg (trunk pipe exclusive) Control Unit: 10kg	